

## CORE Mini

# Installation, Operation & Maintenance Instructions.

Please leave this instruction booklet with the end user as it contains important warranty, maintenance, and safety information.



**Read this manual carefully before commencing installation.**

This manual covers the following products:

**CORE Mini130**

**CORE Mini230**



**PRODUCT DESCRIPTION**

Heating and cooling system pressurisation top up unit with integral water storage tank and electric solenoid piston pump, automated control system consisting of pressure transducer and water level switch. The tank includes an AB air gap for category 5 fluid isolation (BS EN 1717).

**APPLICATION**

The CORE Mini range is designed to provide intermittent water top up only to compensate for intermittent losses in system pressure in heating and cooling systems in commercial or industrial applications. These could include slight leaks, air venting, etc. **The units are not designed to deal with sudden losses of system pressure due to major water losses over extended periods. They are also not to be used for water boosting applications.**

**STORAGE**

If this product is not to be installed immediately on receipt, ensure that it is stored in a dry, frost and vibration free location in its original packaging.

**CONTENTS**

1	WARNINGS.....	3
2	CHECKLIST.....	4
3	IMPORTANT FACTS .....	5
4	LOCATION - GENERAL.....	6
5	KEY FEATURES .....	8
6	INSTALLATION.....	9
7	ELECTRICAL INSTALLATION / EARTHING .....	13
8	COMMISSIONING.....	17
9	OPERATION.....	21
10	MAINTENANCE .....	22
11	ENVIRONMENT PROTECTION.....	23
12	TECHNICAL SPECIFICATION .....	24
13	TROUBLE SHOOTING GUIDE .....	25
14	PRODUCT LOG.....	26
15	THE WARRANTY .....	29

## 1 WARNINGS



- This appliance must not be used for any other application without the written consent of Smith Brothers Stores Ltd.
- This appliance can be used by children aged from 8 years and above and persons with reduced physical, sensory, or mental capabilities or lack of experience and knowledge if they have been given supervision or instruction concerning use of the appliance in a safe way and understand the hazards involved. Children shall not play with the appliance. Cleaning and user maintenance shall not be made by children without supervision.
- Children should be supervised to ensure that they do not play with the appliance.
- This product should not be used for the supply of water to more than one heating/cooling system at a time.
- The electrical installation must be carried out in accordance with the current national electrical regulations.
- The electrical installation must be installed by a qualified person.



- The motor is not accessible in normal operating mode. The unit must only be operated with the front cover in place.
- In the interests of electrical safety, a 30 mA residual current device (R.C.D. not supplied) should be installed in the supply circuit. This may be part of a consumer unit or a separate unit.
- This appliance must be earthed via the supply cord.

Please read installation details carefully as they are intended to ensure this product provides long, trouble free service. Failure to install the unit in accordance with the installation instructions will lead to invalidation of the warranty.

## 2 CHECKLIST

**IMPORTANT:** With the appliance removed from its packaging check for any damage prior to installation. If any damage is found contact Smith Brothers Stores Ltd within 24 hours of receipt.

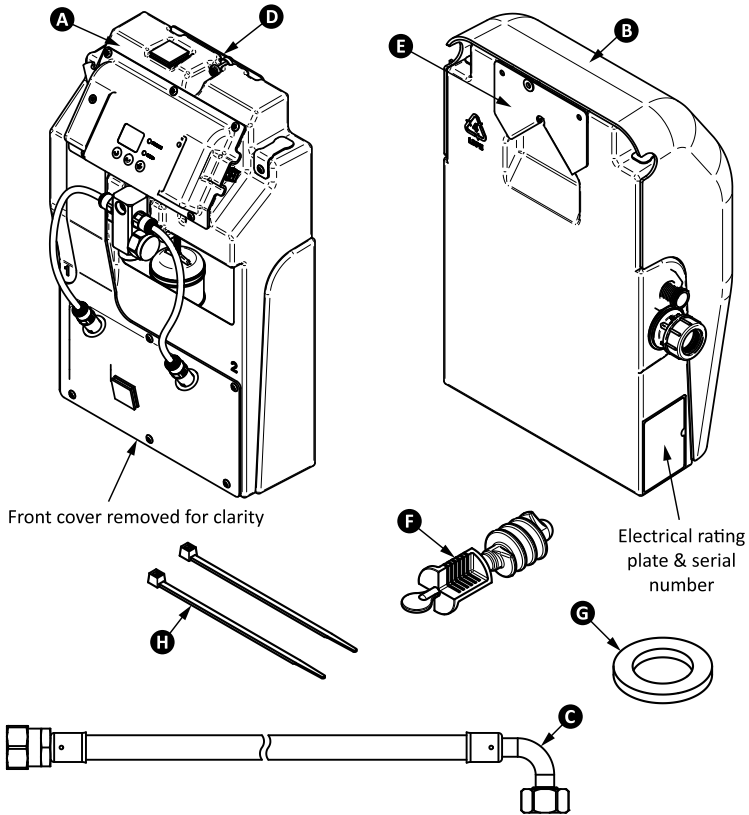

Item	Description	Qty	Item	Description	Qty
A	CORE Mini	1	F	Fill valve flow restrictor, blue	1
B	Front cover	1	G	Rubber hose sealing washer, to be used with item C	1
C	Flexible hose, G ½ 15 mm compression	1	H	Cable tie	2
D	M6 screw	1	I	Instruction book	1
E	Wall mounting plate	1			

Note:

**Your product may vary slightly from the picture above.**

Cont ...

### 3 IMPORTANT FACTS

#### READ BEFORE COMMENCING PUMP INSTALLATION

##### A Water storage capacity.

- 3.11 The CORE Mini has a usable water volume of approximately 2 litres; the length of time the CORE Mini takes to pressurise a system will be dependent on: -  
The pressure differential between the cold fill and set pressures and the refill rate of the tank.
- 3.12 Ensure the pumps are primed as described in the priming section before starting, to avoid causing damage to the pump. See Section 8.20 Hydraulic commissioning.

##### B Water temperature

This unit is designed to pump cold water only which should not exceed the following values:

- 3.13 The maximum allowable water temperature is 23°C (see Section 12).  
3.14 The minimum allowable water temperature is 4°C.

##### C Pipework - General

- 3.15 **Do not** drill holes or put fastenings into the CORE Mini tank, this will cause leakage.
- 3.16 **Secure pipework:** Ensure pipework to and from pump is independently supported & clipped to prevent forces being transferred to inlet and outlet branches of the unit. **Do not** secure pipework to the CORE Mini, this will cause damage and possible leakage.
- 3.17 **Flux:** Solder joints must be completed, and flux residues removed prior to CORE Mini installation (**flux damage will void any warranty**).
- 3.18 **Pipework design:** Care should be taken in the design of pipework runs to minimize the risk of air locks e.g. use drawn bends rather than 90° bends.



- 3.19 **DO NOT** introduce solder flux to flexible hose, tank, pump, or any parts manufactured from plastic.



- 3.20 **DO NOT** allow contact with oil or cellulose based paints, paint thinners or strippers, acid based descalents or aggressive cleaning agents.
- 3.21 **DO NOT** bend the flexible hose beyond 90°. It must be installed as detailed, **DO NOT** kink. See Installation Section 6.14.

##### D Plumbing installation regulations

- 3.22 The plumbing installation must comply with the current water and building regulations.  
3.23 The plumbing installation must be installed by a qualified person.

##### E System filling

- 3.24 The CORE Mini is **NOT DESIGNED TO FILL THE SYSTEM FROM EMPTY**. It is only intended to top up the system after occasional water leakage. Systems should be filled via a dedicated filling loop.

## 4 LOCATION - GENERAL



- 4.11 **Location:** The CORE Mini must be located on a solid wall of sufficient strength to support the filled weight of the CORE Mini, close to the water source and a suitable overflow position (see Section 12 - Technical Specification for filled weight). The CORE Mini must not be installed in a loft space. It must also be considered that the noise and vibration from the CORE Mini may be transmitted through the structure it is sited on. Ensure the minimum clearance requirements are followed to allow servicing of the unit.
- 4.12 **Access and minimum clearance requirements:** For emergencies and maintenance the CORE Mini must be easily accessible and have the minimum clearance around it as laid out in Fig. 2. Additional access to the front of the unit will be required to operate the keypad and view the display.

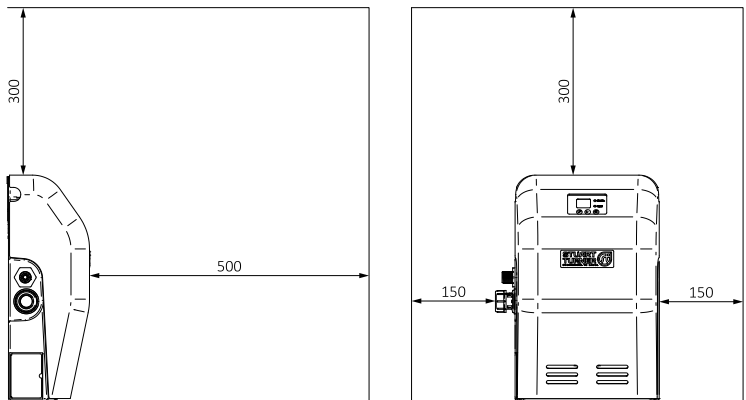

Fig. 2

- 4.13 **Protection:** The CORE Mini must be located in a dry, frost-free area.
- 4.14 **Ventilation:** Ensure an adequate air flow to cool the CORE Mini. Separate the CORE Mini from other appliances that generate heat. **Do not** block the vent holes on the front cover.
- 4.15 **Water retention:** Site the CORE Mini in a location where in the unlikely event of a water leak, any spillage is contained or routed to avoid electrics or areas sensitive to water damage. As part of the AB airgap (CAT 5 fluid isolation) the CORE Mini has a weir type overflow on the front, water will be discharged from this area in the event of the failure of the inlet valve or non-return valve.
- 4.16 **Supply inlet pressure:** The water supply inlet pressure must not exceed 7 bar.
- 4.17 **Ambient temperature:** The CORE Mini must be sited in a location where the ambient temperature does not drop below 4°C or exceed 40°C.
- 4.18 **Pipework:** For optimum performance inlet and outlet pipework must be a minimum of 15 mm pipe.

- 4.19 **Static outlet pressure:** The static outlet head must be 3 metres below the pumps maximum cold fill pressure (vertically above the appliance).
- 4.20 **Noise:** A flexible hose is supplied as standard which will minimise the transmission of noise and vibration from the CORE Mini pump to the pipework connected to the appliance outlet. However, care must be taken when mounting the CORE Mini that any noise is not amplified through loose panels or pipework.
- 4.21 **Flexible hose:** Only use the Smith Brothers Stores Ltd hose supplied with the CORE Mini.
- 4.22 **Isolating valves:** Separate system isolating valves (non-restrictive) must be fitted to allow easy service of the CORE Mini. Isolating valves must be mounted where specified to allow the system isolation and removal of the CORE Mini if needed. See Section 6.14 for installation details.

## 5 KEY FEATURES

5.11 The CORE Mini comprises of the following main components: -

1. **Moulded tank** – Main body of the CORE Mini, comprising of an integrated water tank with warning pipe and weir overflow and mounting the solenoid piston pumps, manifold and controller.
2. **Pump assembly** – One or two piston pump units mounted into the moulded tank with vibration isolating rubber mounts.
3. **Outlet manifold** – Brass manifold with pressure transducer used to monitor system pressure and connection to the pump(s)
4. **Programmable controller** – Custom designed, user set controller, allowing system set up and easy alarm connection.
5. **Wall mounting plate** – Robust stainless steel wall mounting plate allowing quick, easy installation and removal if needed.
6. **Moulded cover** – Moulded acrylic capped ABS cover retained to the moulded tanks with Dual Lock™ fastening system for quick and easy access.

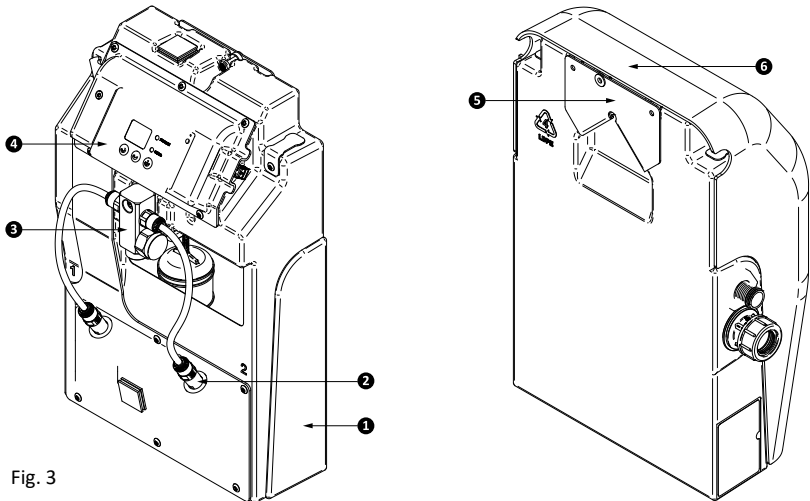

Fig. 3

5.12 **Principle of operation:** The pressurisation unit consists of a break tank and one or two piston pumps. The break tank is supplied with mains water from the left to a float valve and includes an overflow and weir to maintain an AB air gap in the tank. The unit is connected to the heating/chiller system via a flexible hose which can exit the unit on either the left or right. The pumps are connected via a flexible hose to the tank via a rubber connector.

A pressure transducer monitors system pressure and if a reduction in system pressure is detected, the controller runs the pumps until the system is re-pressurised to the required pre-set level. If the unit only has a single pump connected it will run on a 30 minutes on/30 minutes off basis until this level is reached, if the unit is a twin pump model the pumps run in duty standby mode (the controller will alternate which pump starts first to even the wear on the pumps). The manifold is fitted with a non-return valve to ensure system pressure is maintained once pressurised.

Cont ...



## 6 INSTALLATION

6.11 **Fill valve flow restrictor guidelines:** Ensure side entry fill valve is fitted with the correct filter and flow restrictor combination (dependent on the mains water pressure) into the G ½ threaded tail as outlined below:

**Coloured insert** - To be used for water pressure between 1 and 4 bar.

**White insert** - The CORE Mini is pre-fitted with the white high pressure insert. Change if the unit is slow to fill or the water pressure is low (below 4 bar).

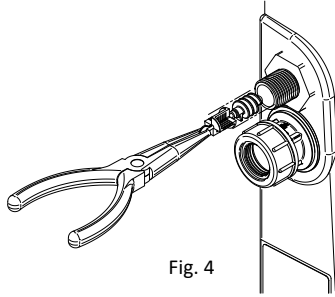

Fig. 4

6.12 **Cold mains feed connection:** The connection to the cold-water mains inlet is made using a suitable fitting to the G ½ male thread on the left hand side of the CORE Mini. When tightening ensure the fill valve within the tank is not rotated. If the valve is rotated it may not function correctly with the risk of flooding. **(Do not overtighten).**

### 6.13 Wall plate fixing:

1. When installing the CORE Mini on a wall ensure suitable fixings for the wall structure are used and are suitable to support the unit when fully filled with water (see Section 10 for filled weights). The holes in the wall plate are 6 mm in diameter, the maximum permissible screw head height is 3 mm.
2. All holes in the wall mounting plate must have fixings used in them as per the image below, do not leave out fastenings as this will compromise the integrity of the wall plate.
3. Ensure you have sufficient room around the area you are mounting the CORE Mini to allow installation, servicing, and operation. See section 4.12.
4. Ensure the wall plate is fixed to a flat vertical wall and the top of the plate is horizontal.

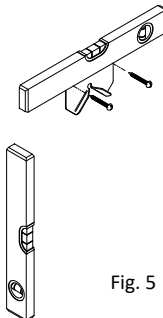

Fig. 5

5. Retain the CORE Mini to the wall mounting plate using the single M6 retaining screw at the top of the wall plate.

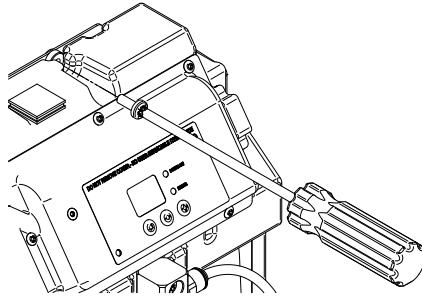

Fig. 6

6. Fit the plastic cover by pressing as indicated below with the palm of the hand as until the Dual Lock™ is heard to 'click'.

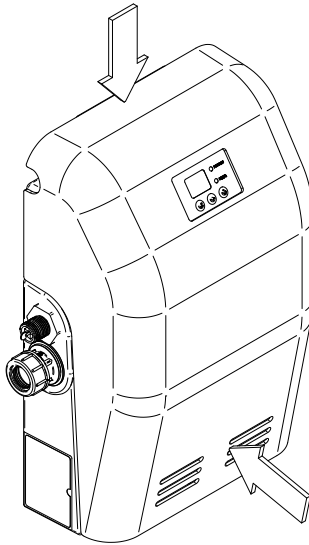

Fig. 7

#### 6.14 Pipework connections & guidelines:

1. Before connecting the CORE Mini to the system ensure that system flushing has been performed correctly and all foreign matter, including pipe scale, has been removed.  
Note: Foreign material from the system coming into contact with the expansion vessel bladder could cause premature failure of the expansion vessel.
2. Isolating valves **MUST** be installed on the unit inlet and outlet before connection to the flexible hoses to allow the unit to be isolated if required. The isolation valve on the outlet should be of a lockshield type. See Fig. 10.
3. A drain valve must be fitted on the outlet of the CORE Mini before the isolation valve. See Fig. 10.
4. The connection to the heating/chilling system is also made with the supplied flexible hose and a 15mm compression fitting. The hose is made watertight with a sealing washer on assembly, nip tight to 4 to 5 Nm for watertight seal. **(Do not overtighten)**.
5. The connection to the heating/chilling system can be made to the left or right hand side by routing the flexible hose supplied as detailed below.

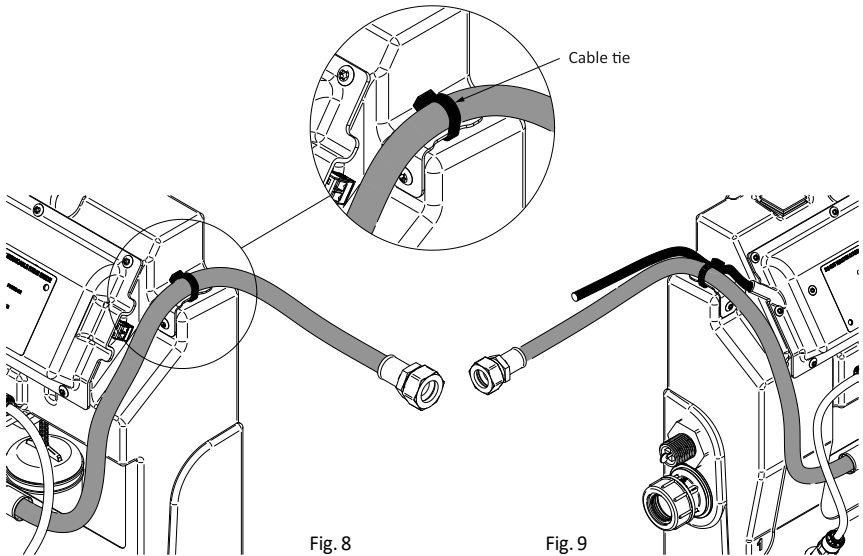

Fig. 8

Fig. 9

Cont ...

6. The flexible hose and any wiring can be retained in the desired position using cable ties and the two metal cable retention points on the top left and right of the CORE Mini tank. See Figs. 8 & 9.
7. The warning pipe should be connected to a suitable drain via a tundish enabling visual warning of an overflow condition. The overflow fitting is designed to use 19 to 23 mm diameter plastic waste pipe or connect to G ¼ threaded pipe. Ensure there is a demountable joint in the pipe to allow the removal of the CORE Mini if needed.
8. Non-return valves, pressure reducing valves and RPZ valves **MUST NOT** be installed between the CORE Mini and the heating/cooling system. These devices will prevent the pressure sensor from reading the system pressure and will lead to incorrect operation of the unit.
9. The CORE Mini should be connected to the system return header along with the expansion vessels as specified in BS 7074. See Fig. 10.

#### 6.15 Typical installation diagram:

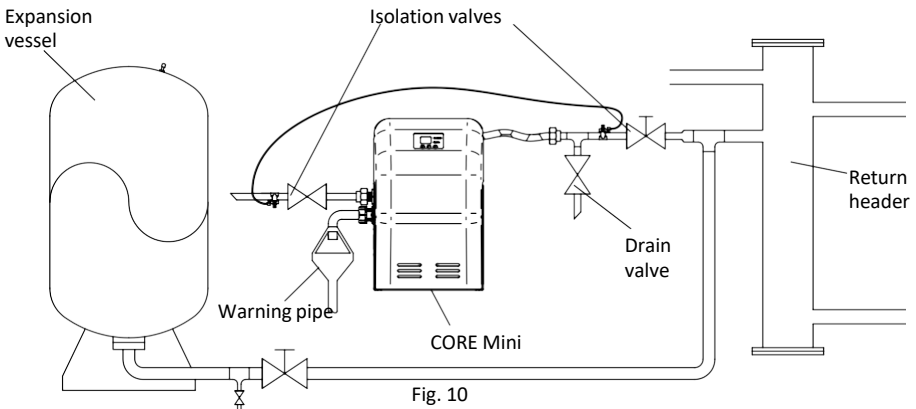

#### 6.16 Vessel sizing & location:

1. System expansion vessel sizing should comply with the BS 7074 Expansion Vessel sizing calculation.
2. The pressurisation unit and expansion vessels should be connected to the system at the same point, to provide a neutral pressure reading.
3. A lockshield valve and drain valve should be installed at the inlet of each expansion vessel to allow for servicing.

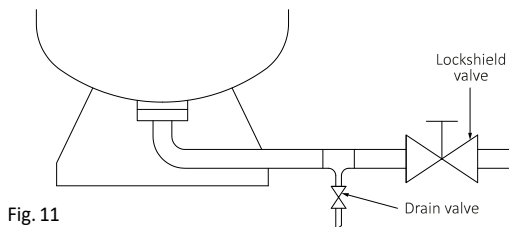

## 7 ELECTRICAL INSTALLATION / EARTHING



- 7.11 **Regulations:** The electrical installation must be carried out in accordance with the current national electrical regulations and installed by a qualified person.
- 7.12 **Safety:** In the interests of electrical safety a 30 mA residual current device (**R.C.D. not supplied**) should be installed in the supply circuit. This may be part of a consumer unit or a separate unit.
- 7.13 Before starting work on the electrical supply ensure the power supply is isolated.
- 7.14 **DO NOT** allow the supply cord to contact hot surfaces, including the motor shell, pump body or pipework. The cord should be safely routed and secured by cable clips.
- 7.15 **Adjacent pipes:** Adjacent suction and delivery pipes should be fitted with earthing clamps in accordance with current regulations (Fig. 12).

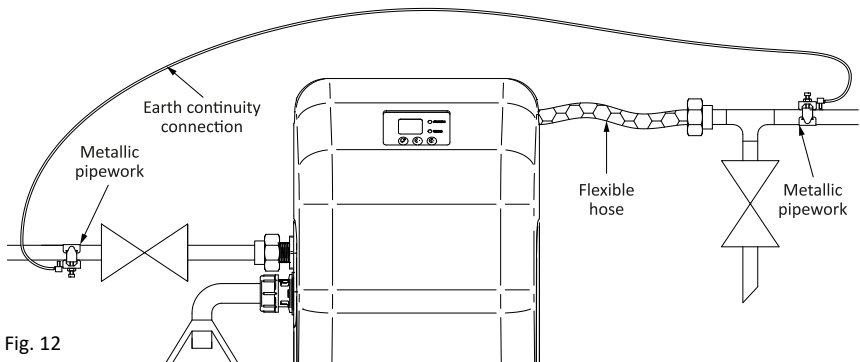

Fig. 12

- 7.16 **Earthing:** This appliance must be earthed via the supply cord.
- 7.17 **Pipework:** Copper or metallic pipework must have supplementary earth bonding where the continuity has been broken by flexible hoses or plastic components.
- 7.18 **Additional earthing:** Certain installations may require additional earthing arrangements such as equipotential bonding. Reference should be made to the relevant regulations concerning this subject to ensure compliance.
- 7.19 **Connections:** The CORE Mini must be connected to a dedicated fused spur via a lockable isolator to avoid unauthorized disconnection.
- 7.20 The electrical connection **must be** made adjacent to (not behind) the CORE Mini to allow disconnection of the electrical supply should the pump module need to be removed for service or maintenance.

Cont ...

### 7.21 Wiring of connection unit:



**WARNING: This appliance must be earthed.**

The wires in the mains lead (supply cord) are coloured in accordance with the following code:

Green and Yellow: Earth

Blue: Neutral

Brown: Live

As the colours of the wires in the mains lead of this appliance may not correspond with the coloured markings identifying the terminals in your connection unit proceed as follows:

- The wire which is coloured green and yellow must be connected to the terminal in the connection unit which is marked with the letter E or by the earth symbol:  or coloured green or green and yellow.
- The wire which is coloured blue must be connected to the terminal which is marked with the letter N or coloured black.
- The wire which is coloured brown must be connected to the terminal which is marked with the letter L or coloured red.

### 7.22 Boiler interlock safety function:

The CORE Mini is fitted with a single volt free contact specifically assigned for boiler/chiller shut down in the event that the CORE Mini detects system pressure above the **Hi alarm** pressure or below the **Lo alarm** pressure.

The boiler interlock contact will be an open circuit below the **Lo alarm** pressure and above the **Hi alarm** pressure.

When the system pressure is in its normal operating pressure range (above **Lo alarm** pressure and below **Hi alarm** pressure settings) the contact is closed circuit.

Always refer to the boiler/chiller manufacturer's instructions for correct integration.

7.23 **Boiler interlock connections:**



The circuit connected to the relay is limited to 5 Amps, 230 V a.c. maximum. The Installer **MUST** fit a 5 Amp fuse in the circuit to the alarm relay to protect the CORE Mini from damage.

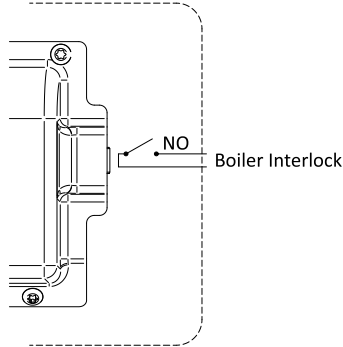

Fig. 13

**For connection of output relays follow the steps and images below:**

- 1) Remove the required green connector from the right-hand side of the control board.

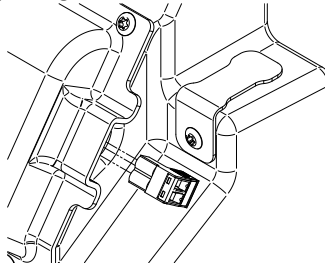

Fig. 14

- 2) Strip 6-8 mm insulation from the end of the connection wire (Max 1.5 mm<sup>2</sup> CSA).

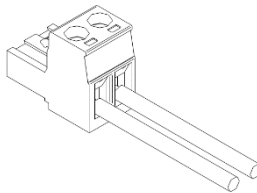

Fig. 15

- 3) Insert wire into connector and screw down terminal screws to secure (0.6 Nm max.).

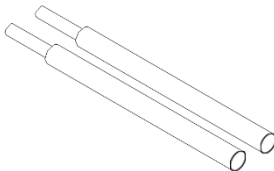
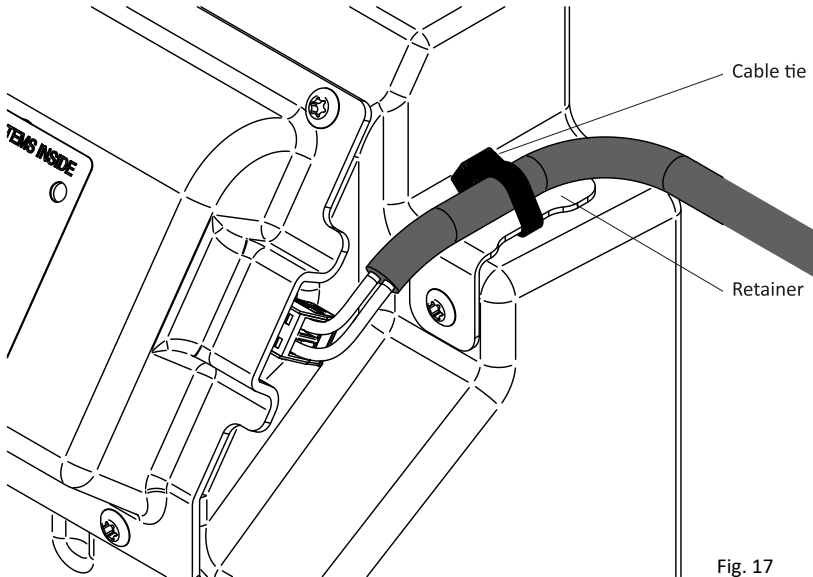

Fig. 16

- 4) Re-insert connector into the correct location on the control board and route the cable to the back of the CORE Mini and secure with a cable tie to the retainer.



7.24 **Fuses:** The following fuse size should be used:

Model	Fuse Size (AMPS)
All models	5

7.25 **Supply cord replacement:**



**The supply cord and internal wiring within the terminal box are routed and secured to ensure compliance with the electrical standard EN 60335-1. It is essential that prior to any disturbance of this internal wiring, all cable routing and securing details are carefully noted to ensure re-assembly to the same factory pattern is always maintained.**

If the supply cord is to be changed or is damaged, it must be replaced with a special cord assembly, please contact Smith Brothers Stores Ltd for further details.

On disassembly note the cord retention and routing system. Re-assemble to the same pattern.

For information on cable connection consult the wiring diagram (Section 10.12).



## 8 COMMISSIONING

### 8.11 Pre-commissioning checklist:

Before starting the commissioning process the following conditions must be met. If these conditions are not adhered to, damage to the equipment, system and property may result.

- Ensure the unit is sited in a frost-free area, away from precipitation and water sprays/jets.
- All necessary pipe/electrical connections should have been made to a satisfactory standard by a qualified person.
- The temperature and pressure at the point of connection are within the operating limits of the pressurisation unit.
- The heating/cooling system is fitted with a safety valve and expansion vessel sized appropriately.

### 8.12 In order for the pressurisation unit and heating/cooling system to function correctly the following conditions must be met. If these conditions have not been met, the commissioning process should not continue.

- Ensure the system connection has been made into the heating/chiller system return header.
- Ensure Non-return valves, pressure reducing valves or RPZ valves are **NOT** installed between the pressurisation unit and the heating/cooling system.
- The expansion vessel is pre-charged to the correct pressure (equal to initial system design pressure).

### 8.13 Prior to commissioning, fill the heating/cooling system via a filling loop. The CORE Mini is **NOT** designed to fill the system from empty, it is only intended to top up the system after occasional water leakage.

- Ensure the heating/cooling system is filled and pressurised to the required cold fill pressure, with the water at approximately ambient temperature.
- Ensure the system is dosed with a suitable corrosion inhibitor. Note the CORE Mini is not designed for dosing chemicals into the system, this must be done via other means.

### 8.14 Expansion vessel setting:

- To set or check the expansion vessel charge pressure the lock-shield valve between the CORE Mini and the vessel must be closed, and the vessel drained using the drain valve.
- A suitable gauge should be used to check the charge pressure.
- If the charge pressure is too high, it can be reduced by releasing air from the vessel pre-charge valve or by using a pressure gauge with an integral air release valve.
- If the charge pressure is too low a small increase can be provided using a car foot pump, otherwise an oil free compressor or nitrogen bottle is recommended.
- When the correct pressure is set the Schrader valve protective cap must be replaced.
- Check the integrity of the pipework. Ensure the lock-shield valve between the system and the expansion vessel is open and the drain valve is closed.

### 8.15 Controller overview

The CORE Mini controller is designed to be intuitive to use and allows functions and alarms to be set by the installer/user.

The functions are set using the 3 buttons (A, B, & C) on the front of the controller and

Cont ...

with the help of on-screen prompts via the back lit LCD display. On the front of the CORE Mini a green 'power on' light will be displayed whilst the unit is powered. If an alarm or error is raised the red 'Error' light will be displayed.

A number pressure set points can be set using the menus, these set points are detailed below, 1 to 4 and in the description of the function.

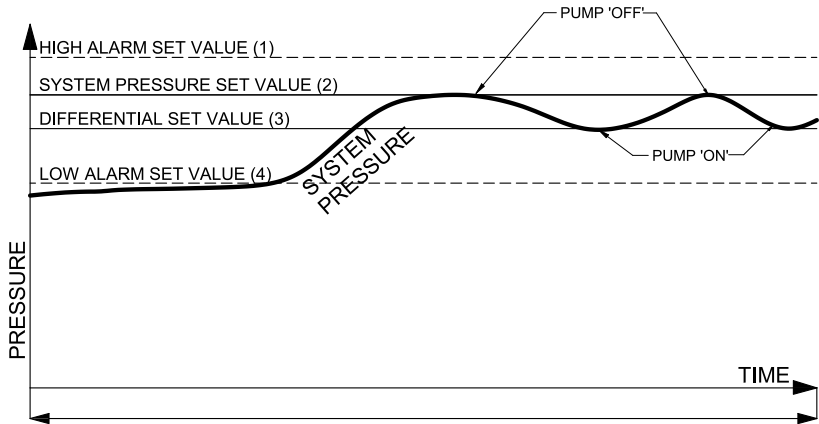

Fig. 18

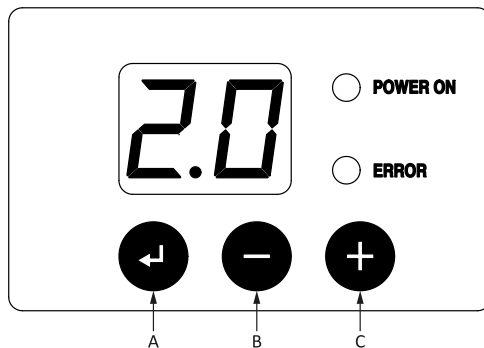

Fig. 19

- Button A Enters menus or selects values.
- Button B Scrolls down through menus or reduces set values.
- Button C Scrolls up through menus or increases set values.

**8.16 Function list & explanation**

The functions are contained within an initial display and a settings menu.

**8.17 Initial display**

On start up, and during normal operation, if the CORE Mini has had no button inputs for 1 minute, the system pressure will be displayed (see Section 9.11).

**8.18 Setting of CORE Mini** see Fig. 19

To access the setting of the CORE Mini see the following procedure:

- 1 Press and hold button A for 5 seconds.
- 2 P1 will be displayed, and the red Error light will slowly flash. See Fig. 20.
- 3 Using buttons B & C select the P function required.
- 4 Press button A to enter the function.
- 5 Using buttons B & C increase the value required up and down.
- 6 Press button A to confirm setting.
- 7 Press and hold button A until the red Error light stops flashing and the CORE Mini reverts to normal operation. This operation will save the changed values.

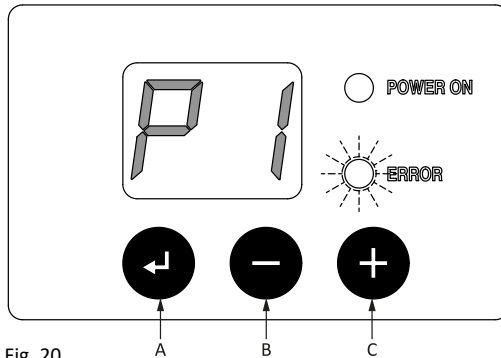

Fig. 20

If no button inputs are received within 1 minute the CORE Mini will revert to normal operation and the red Error light will stop flashing.

Note – Pumps do not operate when in the setting menu.

The following functions can be set and modified: -

<p><b>P1 System pressure (2)</b> see Fig. 18</p>	<p><b>Sets the required system pressure.</b> Set in 0.1 bar increments up to the maximum set value for the CORE model. CORE Mini130 &amp; CORE Mini230, 3.0 bar max.</p>
<p><b>P2 Differential pressure (3)</b> see Fig. 18</p>	<p><b>Sets the pressure the CORE Mini will turn on at as the system pressure falls. Relative to the set system pressure.</b> Set in 0.05 bar increments below the System pressure (2), cannot be set above 0.1 bar below the System pressure (2).</p>
<p><b>P3 Hi Alarm (1)</b> see Fig. 18</p>	<p><b>Sets high system pressure alarm.</b> Set in 0.05 bar increments above the System pressure (2). Cannot be set below System pressure + 0.5 bar. Alarm auto resets when system pressure is reduced below alarm level.</p>

Cont ...

<b>P4 Lo Alarm (4)</b> see Fig. 18	<b>Sets low system pressure alarm.</b> Set in 0.05 bar increments below the System pressure (2) - Differential pressure (3) - 0.05 bar. Alarm auto resets when system pressure is increased above alarm level
<b>P5 Pump number</b>	<b>Sets number of pumps fitted to CORE Mini.</b> 1 or 2 pumps. Factory set to suit model.
<b>P6 Pump test</b>	<b>Allows pump 1 or 2 to be forced to run for 15 seconds to confirm operation.</b> Using buttons A or B to select pump 1 or 2, then press button A or B again to run the pump.
<b>P7 Info.</b>	<b>Displays software revision.</b> No inputs.

#### 8.19 Pre-set values

The CORE Mini will be delivered with the following pre-set values: -

<b>Set Pressure</b>	2 bar
<b>Differential</b>	0.2 bar
<b>Hi Alarm</b>	2.5 bar
<b>Lo Alarm</b>	1.3 bar

#### 8.20 Hydraulic commissioning:

- Ensure both inlet and outlet hydraulic connections are made and watertight.
- Turn on water supply to CORE Mini – Check for leakage and operation of fill valve.
- Allow the tank to fill and water level to stabilise. Adjust the float of the fill valve to set the water level if needed.
- Close isolation valve on the outlet of the CORE Mini.
- Turn the electrical supply **ON** to the CORE Mini. The system pressure will be displayed.
- The CORE Mini will run briefly and then turn off after a pre-set run on time. Due to the small size of the isolated system the CORE Mini will signal a Hi pressure error and the red error light will illuminate on the front of the CORE Mini, this is normal.
- Open the isolation valve on the outlet of the CORE Mini and the CORE Mini will run and start to top the system up.

8.21 **For further technical support:** Phone the Technical Helpline on +44 (0) 1785 218 206. Our staff are trained to help and advise you over the phone.

## 9 OPERATION

### 9.11 Normal operation:

The 'Home' screen will display the status of the system pressure.

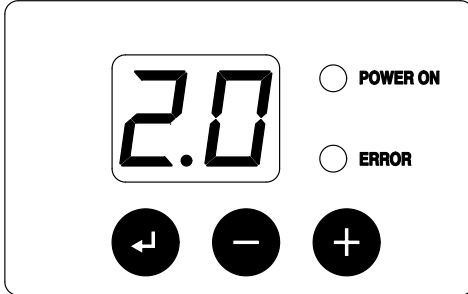

Fig. 21

A green 'Power on' light will be displayed on the front of the CORE Mini.

During normal operation the CORE Mini will monitor the system pressure and re-pressurise the system if the system pressure drops below the system pressure – differential pressure. See Fig. 18.

Example: System pressure 2 bar, differential pressure 0.5 bar, pump will start to re-pressurise system at 1.5 bar system pressure and stop at a system pressure of 2 bar.

During the normal operation of a pressurised system, the system pressure will fluctuate due to temperature changes causing expansion and contraction.

When setting the differential pressure for the Hi \ Lo alarms, please ensure that the normal system pressure fluctuations are below the Hi pressure alarm setting and above the differential pressure. If this is not done the CORE Mini will try to compensate for the pressure change causing an over pressure within the system or alarms being triggered.

### 9.12 Error and alarm display:

The following errors are shown on the display:

- Hi Pressure monitored by the CORE Mini is above the Hi alarm set pressure. Display will flash between Hi and system pressure and red error light will illuminate. Pumps will not run in this condition.
- Lo Pressure monitored by the CORE Mini is below the Lo alarm set pressure. Display will flash between Lo and system pressure and red error light will illuminate. Pumps will run in this condition.
- Er The input signal from the pressure sensor is outside its normal range. The display will flash Er and red error light will illuminate.

## 10 MAINTENANCE

### 10.11 Routine maintenance & service checks:

Every 6 & 12 months (see Section 14 - service log) the CORE Mini should be inspected for: -

- Damage to the electrical supply cable.
- Damage to the outlet flexible hoses.
- Leakage from the CORE Mini or the connecting pipework.
- Test unit operation.
- Float valve check.
- Water condition check.
- Expansion vessel pre-charge check.

### 10.12 Wiring diagram

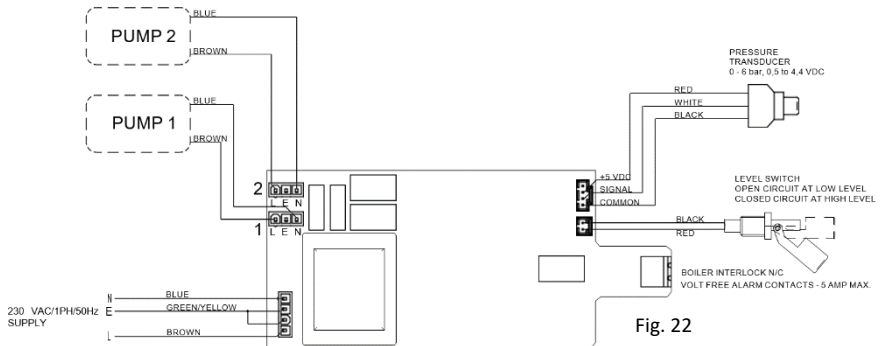

Fig. 22

There are no user serviceable wiring or components inside the controller assembly.

**DO NOT** remove the retaining screws or the membrane cover over the display.

### 10.13 Long term isolation and restart procedure

If the system is to be shut down for an extended period of time due to maintenance or system modifications being carried out to the system, the following steps must be taken.

1. Isolate mains inlet water from the CORE Mini.
2. Isolate the CORE Mini from the system and vent excess pressure to drain.
3. Run the CORE Mini to pump excess water from the tank to drain.
4. Isolate the electrical supply from the CORE Mini.
5. **Ensure the CORE Mini cannot freeze.** Damage **will** occur to the pumps if this is allowed to happen.
6. Cover with plastic sheet or cardboard if work is to be conducted close to the CORE Mini.

#### 10.14 Restart

To ensure the CORE Mini is in good working order after a prolonged period of maintenance the following steps should be taken.

1. Inspect the CORE Mini for signs of damage.
2. Check CORE Mini tank for debris, remove debris and clean tank if needed. Debris may cause damage to the pumps if it is allowed to be drawn in.
3. Check pressure vessel pre charge pressures before the system pressure is increased.
4. Open the mains water isolating valve allowing the CORE Mini tank to fill and ensure the fill valve is operating correctly and maintaining the correct water level.
5. Check for signs of leakage.
6. Open the drain valve on the outlet of the CORE Mini.
7. Turn on the mains electrical power and ensure both (if fitted) pumps can run (use test pump option P6 if needed) and are pumping water to drain.
8. Close the drain valve and allow the CORE Mini to build pressure; the CORE Mini should turn off as the isolation valve to the system is closed.
9. Open the CORE Mini outlet isolation valve and monitor the CORE Mini to ensure there are no leaks as the system pressure increases.
10. Check all the preset values on the CORE Mini, to ensure they are still suitable for the system (after maintenance/modification)

## 11 ENVIRONMENT PROTECTION

Your appliance contains valuable materials which can be recovered or recycled.

At the end of the products' useful life, please leave it at an appropriate local civic waste collection point.

## 12 TECHNICAL SPECIFICATION

Pump Model		CORE Mini130	CORE Mini230
General	Warranty	2 year	
	Approvals	UKCA, CE	
Features	System capacity	Up to 6,000 litres	
	Mounting	Wall mount	
	Pump control system	✓	✓
	Intelligent control interface	✓	✓
	System fill mode	-	-
	Dry run protection	✓	✓
	Typical noise	60 dB(A)	60 dB(A)
Materials	Break tank	Polyethylene	
	Front cover	Acrylic capped ABS	
Performance	Maximum fill pressure	3.0 bar (300 kPa)	
	Maximum flow	1 l/min	
	Maximum inlet pressure - tank fill valve	7 bar (700 kPa)	
	Maximum working pressure	6 bar	
	Ambient air temperature	Min 4°C / Max 40°C	
	Relative humidity	95 % non-condensing	
	Min./Max. water temperature	Min 4°C / Max 23°C	
Water tank	Usable water capacity	2 litres	
	Inlet valve and fill rate	Torbeck (side entry) 12 l/min	
	Fluid category	CAT 5 (type AB air gap with weir)	
Connections	Cold water inlet	G ½ male	
	Cold water outlet - flexible hose	15 mm compression x 600 flexible hose	
	Overflow	G ¾ (19 - 23 mm diameter pipe compression fitting)	
Pump	Number of pumps / pump mode	1 / Duty	2 / Duty-standby
	Pump type / motor type	Solenoid / piston	
	Duty rating (unit)	Int 30 mins on/30 mins off (S3)	Continuous (S1)
	Pump head and seal	PA66/POM NBR	
Electrical	Power supply (Vac/Ph/Hz)	230/1/50	
	Power consumption - P1	100 Watts	
	Current - full load	0.5 Amps	
	Fuse rating	5 Amps	
	Power cable length	1.5 metres (pre-wired)	
	Alarm output	Single	
Physical	Enclosure protection	IPX4	
	Width	293 mm	
	Depth	145 mm	
	Height	403 mm	
	Weight - including fittings	3.6 Kg	4.2 Kg
	Weight - filled	6.6 Kg	7.2 Kg

Smith Brothers Stores Ltd reserve the right to amend the specification without notice.

12.11 **Noise:** The equivalent continuous A-weighted sound pressure level at a distance of 1 metre from the pump does not exceed 70 dB(A).



## 13 TROUBLE SHOOTING GUIDE

Symptoms	Error Code	Probable Cause	Recommended Action
Pump(s) not starting	Low water  Sensor error	No power to CORE Mini  Low water in tank  System pressure = set pressure  Pressure sensor fault	Ensure the green light is on the front of the CORE Mini, check fuse.  Depress float valve to verify water is filling tank, check water level and supply.  CORE Mini functions correctly. Check the set system pressure.  Remove pressure from the CORE Mini outlet and verify the displayed pressure is 0 bar. Er will be displayed if the sensor signal is outside parameters. (Replace sensor – call Smith Brothers Stores Ltd).
Pump(s) will not stop	Sensor error	System pressure set too high.  Pressure sensor fault	System set pressure is set higher than the pump performance capability, reduce set pressure. Ensure you have purchased the correct CORE Mini for the system pressure required.  Remove pressure from the CORE Mini outlet and verify the displayed pressure is 0 bar. Er will be displayed if the sensor signal is outside parameters. (Replace sensor – call Smith Brothers Stores Ltd).
Low pressure alarm triggered	Low pressure  Sensor error	Leak in system.  Low pressure alarm set too high.  Pressure sensor fault	Check system for leaks. Check for leaking pressure relief valve.  Reduce Low press alarm pressure. Check system pressure range during normal operation.  Remove pressure from the CORE Mini outlet and verify the displayed pressure is 0 bar. Er will be displayed if the sensor signal is outside parameters. (Replace sensor – call Smith Brothers Stores Ltd).
High pressure alarm triggered	High pressure  Sensor error	System pressure too high  Pressure sensor fault	Check system operation. Increase High pressure alarm set pressure.  Remove pressure from the CORE Mini outlet and verify the displayed pressure is 0 bar. Error will be displayed if the sensor signal is outside parameters. (Replace sensor – call Smith Brothers Stores Ltd).
Sensor failure error	Sensor error	Pressure sensor outside specification	Remove pressure from the CORE Mini outlet and verify the displayed pressure is 0 bar. Er will be displayed if the sensor signal is outside parameters. (Replace sensor – call Smith Brothers Stores Ltd).
Water overflowing warning pipe or weir		Water level too high Manifold NRV leaking	Check function of the fill valve, replace or adjust if needed.  Isolate CORE Mini from system and mains water and replace non-return valve and manifold.

## 14 PRODUCT LOG

### 14.11 Customer details

Customer/company name	
Site address	
Date	

### 14.12 Equipment details

System volume m <sup>3</sup>	
Expansion vessel(s) fitted & pre-charge pressure	
Boiler(s) fitted	

### 14.13 Commissioning record

Date commissioned	
Company	
Engineer	
System set pressure	
Differential pressure	
Hi alarm set pressure	
Lo alarm set pressure	

### 14.14 Service Log

Service No. 1			
Date			
Engineer name			
Company name			
Tel. No			
System pressure bar			
Differential pressure bar			
<b>Check</b>		6 months	12 months
Condition of wiring		✓	✓
Condition of hoses		✓	✓
Evidence of leakage		✓	✓
Test pump operation		✓	✓
Float valve operation		x	✓
Level probe operation		x	✓
Water condition		x	✓
Exp. vessel pre-charge		x	✓
Comments			

Cont ...

<b>Service No. 2</b>			
Date			
Engineer name			
Company name			
Tel. No			
System pressure bar			
Differential pressure bar			
<b>Check</b>		<b>6 months</b>	<b>12 months</b>
Condition of wiring		✓	✓
Condition of hoses		✓	✓
Evidence of leakage		✓	✓
Test pump operation		✓	✓
Float valve operation		x	✓
Level probe operation		x	✓
Water condition		x	✓
Exp. vessel pre-charge		x	✓
Comments			

<b>Service No. 3</b>			
Date			
Engineer name			
Company name			
Tel. No			
System pressure bar			
Differential pressure bar			
<b>Check</b>		<b>6 months</b>	<b>12 months</b>
Condition of wiring		✓	✓
Condition of hoses		✓	✓
Evidence of leakage		✓	✓
Test pump operation		✓	✓
Float valve operation		x	✓
Level probe operation		x	✓
Water condition		x	✓
Exp. vessel pre-charge		x	✓
Comments			

Service No. 4			
Date			
Engineer name			
Company name			
Tel. No			
System pressure bar			
Differential pressure bar			
<b>Check</b>		6 months	12 months
Condition of wiring		✓	✓
Condition of hoses		✓	✓
Evidence of leakage		✓	✓
Test pump operation		✓	✓
Float valve operation		x	✓
Level probe operation		x	✓
Water condition		x	✓
Exp. vessel pre-charge		x	✓
Comments			

Service No. 5			
Date			
Engineer name			
Company name			
Tel. No			
System pressure bar			
Differential pressure bar			
<b>Check</b>		6 months	12 months
Condition of wiring		✓	✓
Condition of hoses		✓	✓
Evidence of leakage		✓	✓
Test pump operation		✓	✓
Float valve operation		x	✓
Level probe operation		x	✓
Water condition		x	✓
Exp. vessel pre-charge		x	✓
Comments			

Cont ...

## 15 THE WARRANTY

Congratulations on purchasing a CORE product.

We are confident this product will provide many years of trouble-free service as all our products are manufactured to the very highest standard.

The Smith Brothers Stores CORE Mini is warrantied to be free from defects in materials or workmanship for 2 years from the date of purchase.

Within the warranty period we will repair, free of charge, any defects in the product resulting from faults in material or workmanship, repairing or exchanging the whole unit as we may reasonably decide.

Not covered by this warranty: Damage arising from incorrect installation, improper use, unauthorised repair, normal wear and tear and defects which have a negligible effect on the value or operation of the product.

Reasonable evidence must be supplied that the product has been purchased within the warranty term prior to the date of claim (such as proof of purchase or the product's serial number).

This warranty is in addition to your statutory rights as a consumer. If you are in any doubt as to these rights, please contact your local Trading Standards Department.

In the event of a claim please telephone '**Technical Helpline**' with proof of purchase and product serial number.

**+44 (0) 1785 218 206**

You should obtain appropriate insurance cover for any loss or damage which is not covered by Smith Brothers Stores Ltd in this provision.

Please record here for your records.

TYPE NO.	SERIAL NO.	DATE PURCHASED



DECLARATION OF CONFORMITY



**Supply of Machinery Regulations - 2008**

EN ISO 12100:2010, EN 809:1998  
+A1:2009/AC:2010

**Electrical Equipment Regulations - 2016**

EN 60335-1:2012/A2:2019, EN  
60335-2-41:2003/A2:2010

**EMC Regulations - 2016**

EN 61000-3-2, EN  
61000-3-3, EN 61000-4-2, EN 61000-4-3,  
EN 61000-4-4, EN 61000-4-5, EN  
61000-4-6, EN 61000-4-11, EN 61000-6-1,  
EN 61000-6-3

**EMF Regulations - 2016**

EN 62233:2008

**RoHS Regulations - 2012**

EN IEC 63000:2018

**Machinery Directive - 2006/42/EC**

EN ISO 12100:2010, EN 809:1998+A1:2009/  
AC:2010

**Low Voltage Directive - 2014/35/EC**

EN 60335-1:2012/A2:2019, EN  
60335-2-41:2003/A2:2010

**EMC Directive - 2014/30/EU**

EN 61000-3-2, EN  
61000-3-3, EN 61000-4-2, EN 61000-4-3, EN  
61000-4-4, EN 61000-4-5, EN 61000-4-6, EN  
61000-4-11, EN 61000-6-1, EN 61000-6-3

**EMF Directive - 1999/519/EC**

EN 62233:2008

**RoHS Directive - 2011/65/EU**

EN IEC 63000:2018

**WEEE Directive - 2012/19/EU**

IT IS HEREBY CERTIFIED THAT THE PRESSURISATION UNIT AS SERIAL NUMBER BELOW, COMPLIES WITH THE ESSENTIAL REQUIREMENTS OF THE ABOVE STATUTORY REGULATIONS & E.U. DIRECTIVES.



SMITH BROTHERS STORES LIMITED,  
UNIT V2 WINCHESTER AVENUE BLABY,  
LEICESTER. LE8 4GZ

RESPONSIBLE PERSON AND MANUFACTURER

Signed *Andrew Raine*  
ANDREW RAINE | SUPPLY CHAIN DIRECTOR

EU AUTHORISED REPRESENTATIVE

ARC (AUTHORISED REP COMPLIANCE)  
GND FLOOR, 71 LOWER BAGGOT  
STREET, DUBLIN,  
D02 P593, IRELAND.



Smith Brothers Stores Limited reserves the right to amend specifications without notice.  
CORE is a registered trademark owned by Smith Brother Stores Ltd  
Registered Office, Unit V2 Winchester Avenue Blaby, Leicester. LE8 4GZ

