

CORE Midi

Installation, Operation & Maintenance Instructions.

Please leave this instruction booklet with the end user as it contains important warranty, maintenance and safety information.



Read this manual carefully before commencing installation.

This manual covers the following products:

CORE Midi135

CORE Midi150

CORE Midi235

CORE Midi250



PRODUCT DESCRIPTION

Heating and cooling system pressurisation top up unit with integral water storage tank and electric motor driven peripheral pump, automated control system consisting of pressure transducer and water level sensors. The tank includes an AB air gap for category 5 fluid isolation (BS EN 1717).

APPLICATION

The CORE Midi range is designed to provide initial system fill and intermittent water top up to compensate for intermittent losses in system pressure in heating and cooling systems in commercial or industrial applications. These could include slight leaks, air venting, etc. **The units are not designed to deal with sudden losses of system pressure due to major water losses over extended periods. They are also not to be used for water boosting applications.**

STORAGE

If this product is not to be installed immediately on receipt, ensure that it is stored in a dry, frost and vibration free location in its original packaging.

CONTENTS

1	WARNINGS.....	3
2	CHECKLIST.....	4
3	IMPORTANT FACTS	5
4	LOCATION - GENERAL.....	6
5	KEY FEATURES	8
6	INSTALLATION.....	9
7	ELECTRICAL INSTALLATION / EARTHING	13
8	COMMISSIONING.....	17
9	OPERATION.....	24
10	MAINTENANCE	26
11	ENVIRONMENT PROTECTION.....	27
12	TECHNICAL SPECIFICATION	28
13	TROUBLE SHOOTING GUIDE	29
14	PRODUCT LOG.....	30
15	THE WARRANTY	33

1 WARNINGS



- This appliance must not be used for any other application without the written consent of Smith Brothers Stores Ltd.
- This appliance can be used by children aged from 8 years and above and persons with reduced physical, sensory or mental capabilities or lack of experience and knowledge if they have been given supervision or instruction concerning use of the appliance in a safe way and understand the hazards involved. Children shall not play with the appliance. Cleaning and user maintenance shall not be made by children without supervision.
- Children should be supervised to ensure that they do not play with the appliance.
- This product should not be used for the supply of water to more than one heating/cooling system at a time.
- The electrical installation must be carried out in accordance with the current national electrical regulations.
- The electrical installation must be installed by a qualified person.



- The motor is not accessible in normal operating mode. The unit must only be operated with the front cover in place.
- In the interests of electrical safety a 30 mA residual current device (R.C.D. not supplied) should be installed in the supply circuit. This may be part of a consumer unit or a separate unit.
- This appliance must be earthed via the supply cord.

Please read installation details carefully as they are intended to ensure this product provides long, trouble free service. Failure to install the unit in accordance with the installation instructions will lead to invalidation of the warranty.

2 CHECKLIST

IMPORTANT: With the appliance removed from its packaging check for any damage prior to installation. If any damage is found contact Smith Brothers Stores Ltd within 24 hours of

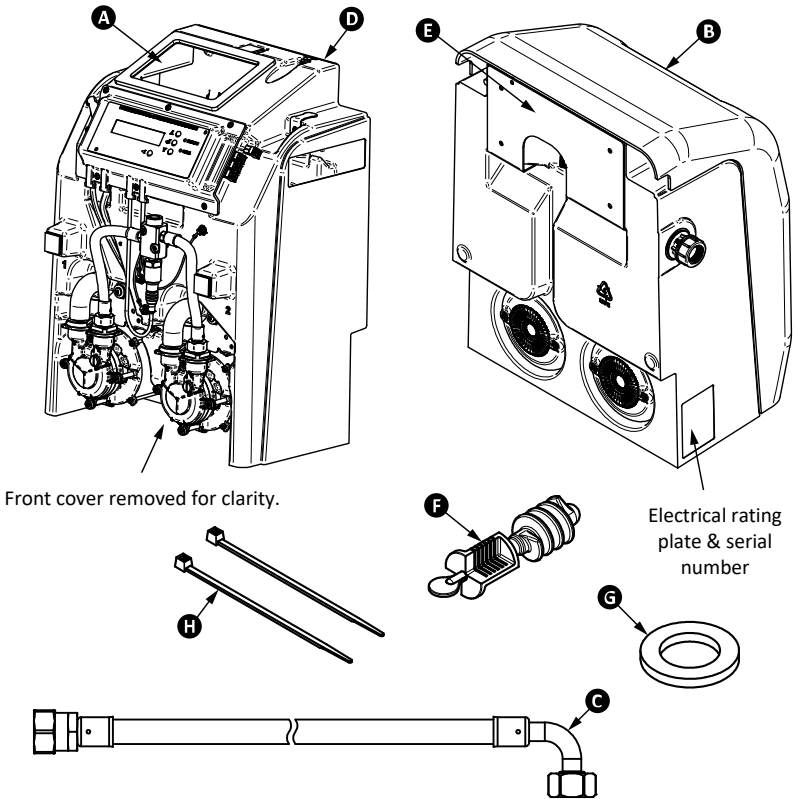

Fig. 1

receipt.

Item	Description	Qty	Item	Description	Qty
A	CORE Midi	1	F	Fill valve flow restrictor	2
B	Front cover	1	G	Rubber hose sealing washer, to be used with item C	2
C	Flexible hose, G ½ 15 mm compression	2	H	Cable tie	2
D	M6 screw	1	I	Instruction book	1
E	Wall mounting plate	1			

Note:

Your product may vary slightly from the picture above.

Cont ...

3 IMPORTANT FACTS

READ BEFORE COMMENCING PUMP INSTALLATION

A Water storage capacity.

- 3.11 The CORE Midi has a usable water volume of approximately 8 litres; the length of time the CORE Midi takes to pressurise a system will be dependent on:-
The pressure differential between the cold fill and set pressures and also the refill rate of the tank
- 3.12 Ensure the pumps are primed as described in the priming section before starting, to avoid causing damage to the pump shaft seal. See Section 8.26 Hydraulic commissioning.

B Water temperature

This unit is designed to pump cold water only which should not exceed the following values:

- 3.13 The maximum allowable water temperature is 23°C (see Section 12).
3.14 The minimum allowable water temperature is 4°C.

C Pipework - General

- 3.15 **Do not** drill holes or put fastenings into the CORE Midi tank, this will cause leakage.
- 3.16 **Secure pipework:** Ensure pipework to and from pump is independently supported & clipped to prevent forces being transferred to inlet and outlet branches of the unit. **Do not** secure pipework to the CORE Midi, this will cause damage and possible leakage.
- 3.17 **Flux:** Solder joints must be completed and flux residues removed prior to CORE Midi installation (**flux damage will void any warranty**).
- 3.18 **Pipework design:** Care should be taken in the design of pipework runs to minimize the risk of air locks e.g. use drawn bends rather than 90° bends.



- 3.19 **DO NOT** introduce solder flux to flexible hose, tank, pump or any parts manufactured from plastic.



- 3.20 **DO NOT** allow contact with oil or cellulose based paints, paint thinners or strippers, acid based descalents or aggressive cleaning agents.
- 3.21 **DO NOT** bend the flexible hose beyond 90°. It must be installed as detailed, **DO NOT** kink. See Installation Section 6.15.

D Plumbing installation regulations

- 3.22 The plumbing installation must comply with the current water and building regulations.
3.23 The plumbing installation must be installed by a qualified person.

4 LOCATION - GENERAL



- 4.11 **Location:** The preferred CORE Midi location is either on a solid wall or on a smooth level floor, both of sufficient strength to support the filled weight of the CORE Midi, close to the water source and a suitable overflow position (see Section 11 - Technical Specification for filled weight). The CORE Midi must not be installed in a loft space. It must also be considered that the noise and vibration from the CORE Midi may be transmitted through the structure it is sited on. Ensure the minimum clearance requirements are followed to allow servicing of the unit
- 4.12 **Access and minimum clearance requirements:** For emergencies and maintenance the CORE Midi must be easily accessible and have the minimum clearance around it as laid out in Fig. 2. Additional access to the front of the unit will be required to operate the keypad and view the display.

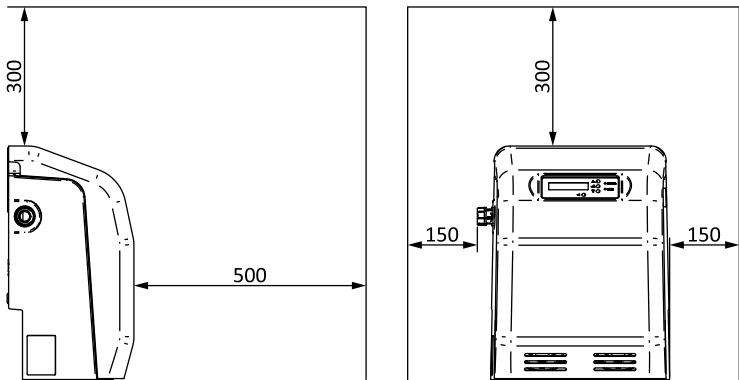

- 4.13 **Protection:** The CORE Midi must be located in a dry, frost free area.
- 4.14 **Ventilation:** Ensure an adequate air flow to cool the CORE Midi. Separate the CORE Midi from other appliances that generate heat. **Do not** block the vent holes on the front cover or the air inlet at the rear.
- 4.15 **Water retention:** Site the CORE Midi in a location where in the unlikely event of a water leak, any spillage is contained or routed to avoid electrics or areas sensitive to water damage. As part of the AB airgap (CAT 5 fluid isolation) the CORE Midi has a weir type overflow on the right hand side, water will be discharged from this area in the event of the failure of the inlet valve or non-return valves.
- 4.16 **Supply inlet pressure:** The water supply inlet pressure must not exceed 7 bar.
- 4.17 **Ambient temperature:** The CORE Midi must be sited in a location where the ambient temperature does not drop below 4°C or exceed 40°C.

Cont ...

- 4.18 **Pipework:** For optimum performance inlet and outlet pipework must be a minimum of 15 mm pipe.
- 4.19 **Static outlet pressure:** The static outlet head must be 3 metres below pump maximum cold fill pressure (vertically above the appliance).
- 4.20 **Noise:** A flexible hose is supplied as standard which will minimise the transmission of noise and vibration from the CORE Midi pump to the pipework connected to the appliance outlet. However, care must be taken when mounting the CORE Midi that any noise is not amplified through loose panels or pipework.
- 4.21 **Flexible hose:** Only use the Smith Brothers Stores Ltd hoses supplied with the CORE Midi.
- 4.22 **Isolating valves:** Separate system isolating valves (non-restrictive) must be fitted to allow easy service of the CORE Midi. Isolating valves must be mounted where specified to allow the system isolation and removal of the CORE Midi if needed. See Section 6.15 for installation details.

5 KEY FEATURES

5.11 The CORE Midi comprises of the following main components:-

1. **Moulded tank** – Main body of the CORE Midi, comprising of an integrated water tank with warning pipe and weir overflow and mounting the brass pump assembly, manifold and controller.
2. **Pump assembly** – One or two brass peripheral pump units powered by induction motors, with integrated non return valves and venting screw. Mounted into the moulded tank with vibration isolating rubber mounts.
3. **Outlet manifold** – Brass manifold with pressure transducer used to monitor system pressure and connection to the pump(s).
4. **Programmable controller** – Custom designed, user set controller, allowing system set up and easy alarm connection.
5. **Wall mounting plate** – Robust stainless steel wall mounting plate allowing quick, easy installation and removal if needed.
6. **Moulded cover** – Moulded acrylic capped ABS cover retained to the moulded tanks with Dual Lock™ fastening system for quick and easy access.

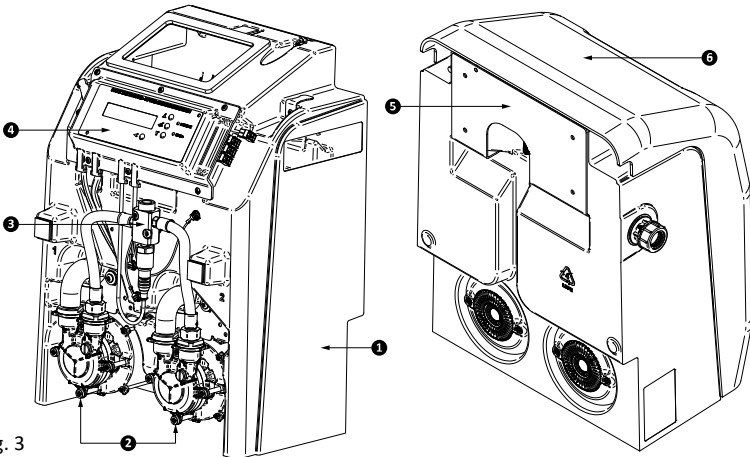

Fig. 3

5.12 **Principle of operation:** The pressurisation unit consists of a break tank and one/two peripheral pumps. The break tank is supplied with mains water from either the left or right through a flexible hose connected to a float valve and includes an overflow and weir to maintain an AB air gap in the tank. The unit is connected to the heating/chiller system via another flexible hose which can exit the unit on either the left or right.

The pumps are connected to the tank via a rubber connector.

A pressure transducer monitors system pressure and if a reduction in system pressure is detected, the controller runs the pumps until the system is re-pressurised to the required pre-set level. If the unit only has a single pump connected it will run continuously until this level is reached, if the unit is a twin pump model the pumps run in duty standby mode (the controller will alternate which pump starts first to even the wear on the pumps). The pumps are fitted with non-return valves to ensure system pressure is maintained once pressurised.

Cont ...

6 INSTALLATION

6.11 **Fill valve flow restrictor guidelines:** The side entry fill valve must be fitted with the correct filter and flow restrictor combination (dependant on the mains water pressure) into the G ½ threaded tail as outlined below:

Coloured insert - To be used for water pressure between 1 and 4 bar

White insert - To be used for water pressure above 4 bar

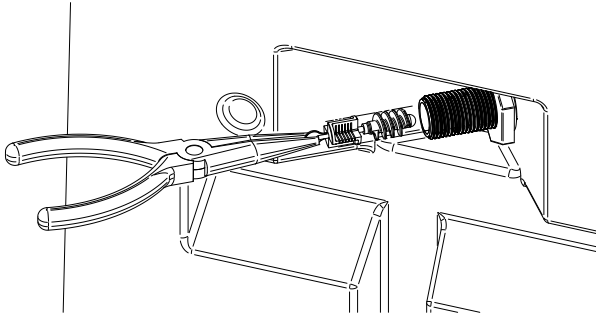

Fig. 4

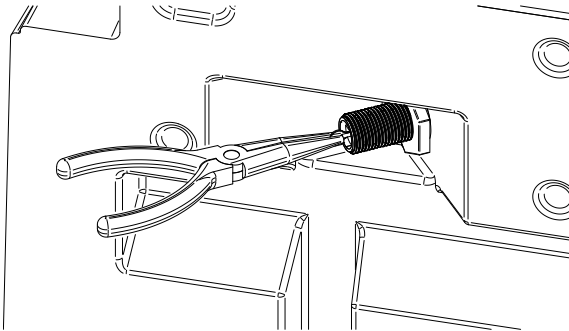

Fig. 5

6.12 **Cold mains feed connection:** The connection to the cold water mains inlet is made using the 15mm compression flexible hose supplied. Ensure the rubber sealing washer supplied with the hose is installed when the hose is fitted. When tightening ensure the fill valve within the tank is not rotated. If the valve is rotated it may not function correctly with the risk of flooding. The hose is made water tight with a sealing washer on assembly, nip tight to 4 to 5 Nm for water tight seal. **(Do not overtighten)**. See Fig. 6.

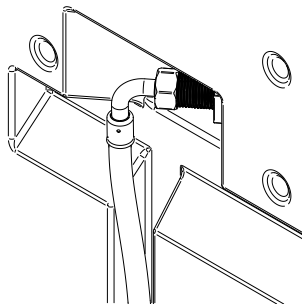

Fig. 6

Cont ...

6.13 Wall plate fixing:

1. If installing the CORE Midi on a wall ensure suitable fixings for the wall structure are used and are suitable to support the unit when fully filled with water (see Section 10 for filled weights). The holes in the wall plate are 6mm in diameter, the maximum permissible screw head height is 3mm.
2. All holes in the wall mounting plate must have fixings used in them as per the image below, do not leave out fastenings as this will compromise the integrity of the wall plate.
3. Ensure you have sufficient room around the area you are mounting the CORE Midi to allow installation, servicing and operation. See section 4.12.
4. Ensure wall plate is fixed to a flat vertical wall and the top of the plate is horizontal.

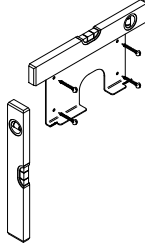

Fig. 7

5. Retain the CORE Midi to the wall mounting plate using the single M6 retaining screw at the top of the wall plate.

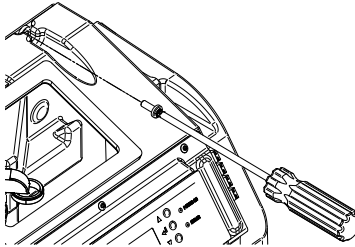

Fig. 8

6. Fit the plastic cover by pressing as indicated below with the palm of the hand as until the Dual Lock™ is heard to 'click'.

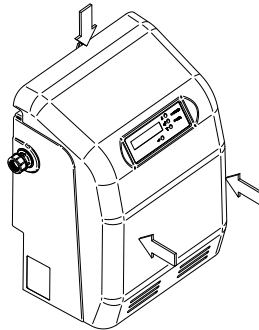

Fig. 9

6.14 Floor installation:

1. If installed on a floor ensure the CORE Midi is located so it cannot be kicked or knocked over.
2. Ensure the floor surface on which the CORE Midi is located is flat and level.
3. If possible locate the unit against a wall for added stability.
4. If the CORE Midi is located in an area that might be subjected to flooding, mount the CORE Midi on a raised plinth.

6.15 Pipework connections & guidelines:

1. Before connecting the CORE Midi to the system ensure that system flushing has been performed correctly and all foreign matter, including pipe scale, has been removed.
Note: Foreign material from the system coming into contact with the expansion vessel bladder could cause premature failure of the expansion vessel.
2. Isolating valves **MUST** be installed on the unit inlet and outlet, before connection to the flexible hoses to allow the unit to be isolated if required. The isolation valve on the outlet should be of a lockshield type. See Fig. 12.
3. A drain valve must be fitted on the outlet of the CORE Midi before the isolation valve. See Fig. 12.
4. The connection to the heating/chilling system is also made with the supplied flexible hose and a 15mm compression fitting. The hose is made water tight with a sealing washer on assembly, nip tight to 4 to 5 Nm for water tight seal. **(Do not overtighten)**.
5. The connection to the heating/chilling system can be made to the left or right hand side by routing the flexible hose supplied as detailed below.

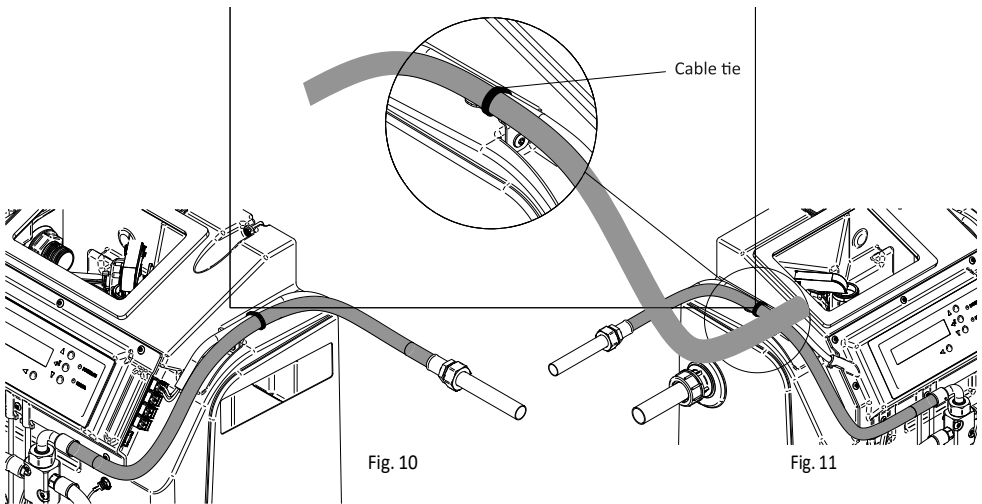

Cont ...

6. The flexible hose and any wiring can be retained in the desired position using cable ties and the two metal cable retention points on the top left and right of the CORE Midi tank. See Figs. 10 & 11.
7. The warning pipe should be connected to a suitable drain via a tundish enabling visual warning of an overflow condition. The overflow fitting is designed to use 19 to 23 mm diameter plastic waste pipe or connect to G ¾ threaded pipe. Ensure there is a demountable joint in the pipe to allow the removal of the CORE Midi if needed.
8. Non-return valves, pressure reducing valves and RPZ valves **MUST NOT** be installed between the CORE Midi and the heating/cooling system. These devices will prevent the pressure sensor from reading the system pressure and will lead to incorrect operation of the unit.
9. The CORE Midi should be connected to the system return header along with the expansion vessels as specified in BS 7074. See Fig. 12.

6.16 Typical installation diagram:

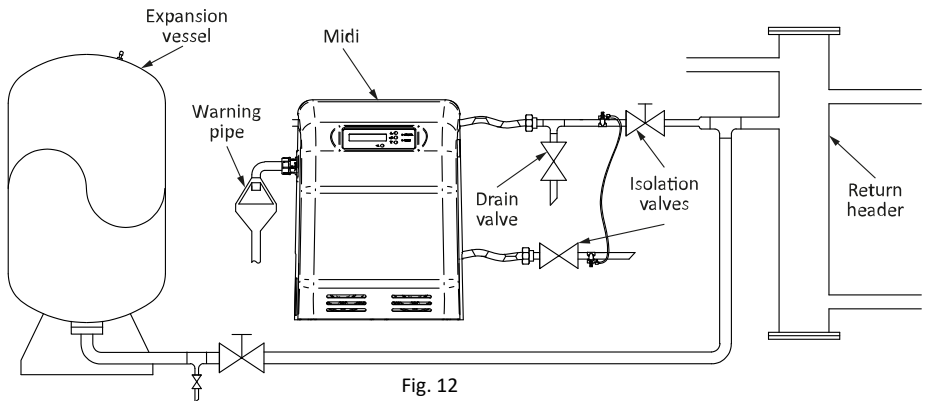

Fig. 12

6.17 Vessel sizing & location:

1. System expansion vessel sizing should comply with the BS 7074 Expansion Vessel sizing calculation.
2. The pressurisation unit and expansion vessels should be connected to the system at the same point, to provide a neutral pressure reading.
3. A lockshield valve and drain valve should be installed at the inlet of each expansion vessel to allow for servicing.

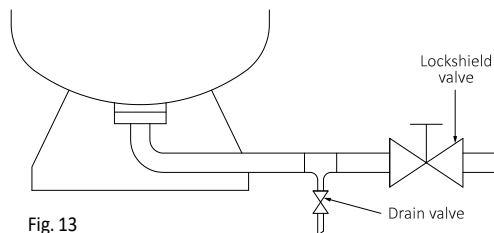

Fig. 13

7 ELECTRICAL INSTALLATION / EARTHING



- 7.11 **Regulations:** The electrical installation must be carried out in accordance with the current national electrical regulations and installed by a qualified person.
- 7.12 **Safety:** In the interests of electrical safety a 30 mA residual current device (**R.C.D. not supplied**) should be installed in the supply circuit. This may be part of a consumer unit or a separate unit.
- 7.13 Before starting work on the electrical supply ensure power supply is isolated.
- 7.14 **DO NOT** allow the supply cord to contact hot surfaces, including the motor shell, pump body or pipework. The cord should be safely routed and secured by cable clips.
- 7.15 **Adjacent pipes:** Adjacent suction and delivery pipes should be fitted with earthing clamps in accordance with current regulations (Fig. 14).

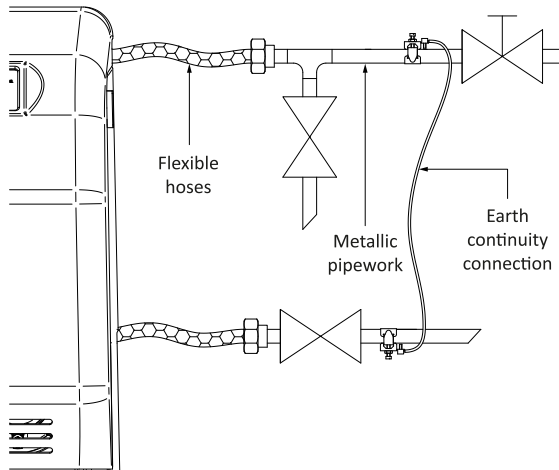

Fig. 14

- 7.16 **Earthing:** This appliance must be earthed via the supply cord.
- 7.17 **Pipework:** Copper or metallic pipework must have supplementary earth bonding where the continuity has been broken by flexible hoses or plastic components.
- 7.18 **Additional earthing:** Certain installations may require additional earthing arrangements such as equipotential bonding. Reference should be made to the relevant regulations concerning this subject to ensure compliance.
- 7.19 **Connections:** The CORE Midi must be connected to a dedicated fused spur via a lockable isolator to avoid unauthorized disconnection.
- 7.20 The electrical connection **must be** made adjacent to (not behind) the CORE Midi to allow disconnection of the electrical supply should the pump module need to be removed for service or maintenance.

7.21 Wiring of connection unit:



WARNING: This appliance must be earthed.

The wires in the mains lead (supply cord) are coloured in accordance with the following code:

Green and Yellow: Earth

Blue: Neutral

Brown: Live

As the colours of the wires in the mains lead of this appliance may not correspond with the coloured markings identifying the terminals in your connection unit proceed as follows:

- The wire which is coloured green and yellow must be connected to the terminal in the connection unit which is marked with the letter E or by the earth symbol:  or coloured green or green and yellow.
- The wire which is coloured blue must be connected to the terminal which is marked with the letter N or coloured black.
- The wire which is coloured brown must be connected to the terminal which is marked with the letter L or coloured red.

7.22 Boiler interlock safety function:

The CORE Midi is fitted with a volt free contact specifically assigned for boiler/chiller shut down in the event that the CORE Midi detects system pressure above the **Hi alarm** pressure or below the **Lo alarm** pressure.

The boiler interlock contact will be open circuit below the **Lo alarm** pressure and above the **Hi alarm** pressure.

When the system pressure is in its normal operating pressure range (above **Lo alarm** pressure and below **Hi alarm** pressure settings) the contact is closed circuit

Always refer to the boiler/chiller manufacturer's instructions for correct integration.

7.23 Alarm and boiler interlock connections:



Circuits connected to the relays are limited to 5 Amps, 230 V a.c. maximum. The Installer MUST fit a 5 Amp fuse in the circuit to the alarm relay to protect the CORE Midi from damage.

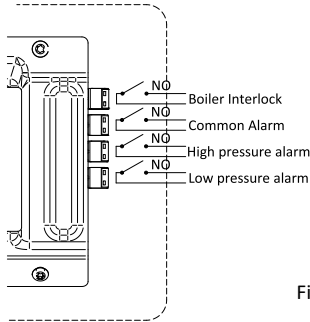

Fig. 15

For connection of output relays follow the steps and images below:

- 1) Remove the required green connector from the right hand side of the control board.

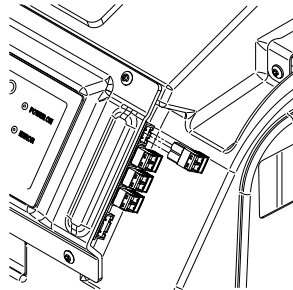

Fig. 16

- 2) Strip 6-8 mm insulation from the end of the connection wire (Max 1.5 mm² CSA).

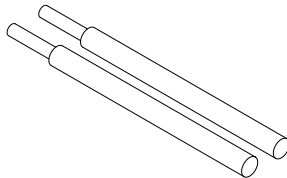

Fig. 17

- 3) Insert wire into connector and screw down terminal screws to secure (0.6 Nm max.).

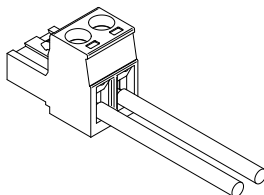

Fig. 18

- 4) Re-insert connector into the correct location on the control board and route the cable to the back of the CORE Midi and secure with a cable tie to the retainer.

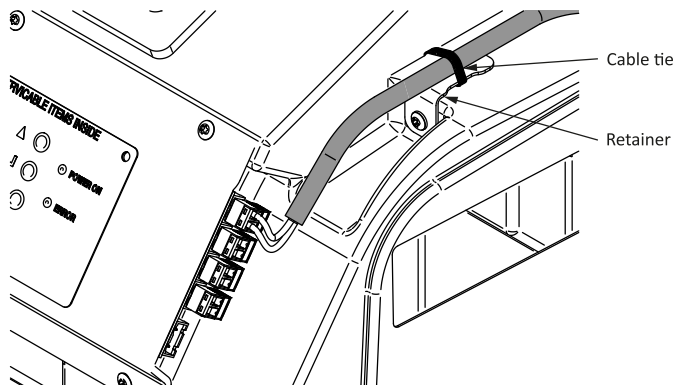

Fig. 19

7.24 RS 485 Modbus – BMS Connection:

RS 485 is available on this product for BMS connection and is enabled in the Advanced settings menu.

7.25 Fuses: The following fuse size should be used:

Model	Fuse Size (AMPS)
All models	5

The CORE Midi is fitted with an internal re-settable fuse, see section 13.

7.26 Supply cord replacement:



The supply cord and internal wiring within the terminal box are routed and secured to ensure compliance with the electrical standard EN 60335-1. It is essential that prior to any disturbance of this internal wiring, all cable routing and securing details are carefully noted to ensure re-assembly to the same factory pattern is always maintained.

If the supply cord is to be changed or is damaged, it must be replaced with a special cord assembly, please contact Smith Brothers Stores Ltd for further details.

On disassembly note the cord retention and routing system. Re-assemble to the same pattern.

For information on cable connection consult the wiring diagram (Section 10.12).

8 COMMISSIONING

8.11 Pre-commissioning checklist:

Before starting the commissioning process the following conditions must be met. If these conditions are not adhered to, damage to the equipment, system and property may result.

- Ensure the unit is sited in a frost free area, away from precipitation and water sprays/jets.
- All necessary pipe/electrical connections should have been made to a satisfactory standard by a qualified person.
- The temperature and pressure at the point of connection are within the operating limits of the pressurisation unit.
- The heating/cooling system is fitted with a safety valve and expansion vessel sized appropriately.

8.12 In order for the pressurisation unit and heating/cooling system to function correctly the following conditions must be met. If these conditions have not been met, the commissioning process should not continue.

- Ensure the system connection has been made into the heating/chiller system return header.
- Ensure Non-return valves, pressure reducing valves or RPZ valves are **NOT** installed between the pressurisation unit and the heating/cooling system.
- The expansion vessel is pre-charged to the correct pressure (equal to initial system design pressure).

8.13 Prior to commissioning fill the heating/cooling system via a filling loop if possible. If this is not possible, the pressurisation unit can be used to fill the system after commissioning has taken place. Depending on the size of the system, this may take a considerable amount of time. The system fill function of the unit will stop after 24 hours, if further filling is required, reset this function.

- Ensure the heating/cooling system is filled and pressurised to the required cold fill pressure, with the water at approximately ambient temperature.
- Ensure the system is dosed with a suitable corrosion inhibitor. Note the CORE Midi is not designed for dosing chemicals into the system, this must be done via other means.

8.14 Expansion vessel setting:

- To set or check the expansion vessel charge pressure the lock-shield valve between the CORE Midi and the vessel must be closed and the vessel drained using the drain valve.
- A suitable gauge should be used to check the charge pressure.
- If the charge pressure is too high it can be reduced by releasing air from the vessel pre-charge valve or by using a pressure gauge with an integral air release valve.
- If the charge pressure is too low a small increase can be provided using a car foot pump otherwise an oil free compressor or nitrogen bottle is recommended.
- When the correct pressure is set the Schrader valve protective cap must be replaced.
- Check the integrity of the pipe-work. Ensure the lock-shield valve between the system and the expansion vessel is open and the drain valve is closed.

8.15 Controller overview

The CORE Midi controller is designed to be intuitive to use and allows functions and alarms to be set by the installer/user. It also allows faults to be monitored and logged to enable easier system fault diagnosis.

The functions are set using the 4 buttons (A, B, C & D) on the front of the controller and with the help of on screen prompts via the back lit LCD display. On the front of the CORE Midi a green 'power on' light will be displayed whilst the unit is powered. If an alarm or error is raised the red 'Error' light will be displayed.

A number pressure set points can be set using the menus, these set points are detailed below, 1 to 4 and in the description of the function.

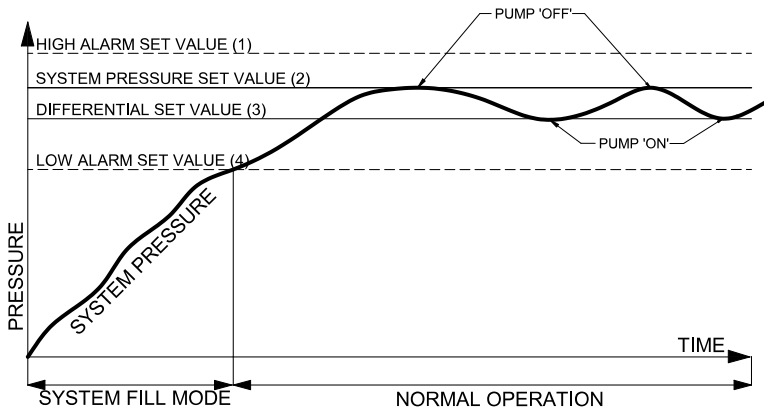

Fig. 20

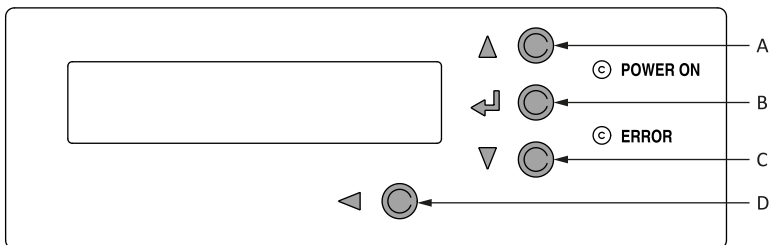

Fig. 21

- Button A Scrolls up through menus or increases set values.
- Button B Enters menus or selects values.
- Button C Scrolls down through menus or reduces set values.
- Button D Returns to previous menu

8.16 Function list & explanation

The functions are contained within an initial display and 3 menus:-

Setting menu (pass code protected) see Section 8.18.

Advanced setting menu (pass code protected) see Section 8.19.

Test menu (pass code protected) see Section 8.20.

8.17 Initial display

On start up, and during operation, if the CORE Midi has had no button inputs for 1 minute, a home screen (see Section 9.11) will be displayed with system pressure, tank water level, any active alarm and any pump that is operating at the time.

By using buttons A & C to scroll up or down the following screens will be displayed:-

- System pressure
- Active errors
- System fill status
- Pump activity
- Pump run time
- Alarm reset

8.18 Setting menu

(Pass code protected, if set)

The following functions can be set and modified:-

<p>System pressure (2) see Fig. 20</p>	<p>Sets the required system pressure. Set in 0.1 bar increments up to the maximum set value for the CORE model. CORE Midi135 & COREMidi 230D, 3.5 bar max., CORE Midi150 & CORE Midi250, 4.1 bar max.</p>
<p>Differential pressure (3) see Fig. 20</p>	<p>Sets the pressure the CORE Midi will turn on at as the system pressure falls. Relative to the system pressure. Set in 0.05 bar increments below the System pressure (2), cannot be set above 0.1 bar below the System pressure (2).</p>
<p>Hi Alarm (1) see Fig. 20</p>	<p>Sets high system pressure alarm. Set in 0.05 bar increments above the System pressure (2). Cannot be set below System pressure + 0.05 bar. Alarm auto resets when system pressure is reduced below alarm level.</p>
<p>Lo Alarm (4) see Fig. 20</p>	<p>Sets low system pressure alarm. Set in 0.05 bar increments below the System pressure (2) - Differential pressure (3) - 0.05 bar. Alarm auto resets when system pressure is increased above alarm level</p>
<p>System fill</p>	<p>Turns on system fill option. System fill option will turn off once the System pressure (2) has been reached or a period of 24 hours has passed since it was set to 'on'. Lo alarm and Max runtime functions are disabled whilst System fill is turned on. Pumps will stop if the System pressure (2) or Hi alarm pressure (1) is reached.</p>
<p>Start Activity High</p>	<p>Alarm triggered if the CORE Midi starts more than the preset limit in 24 Hours. Set to minimum of 100 starts per 24 hrs. Set in increments of 100.</p>

8.19 Advanced setting menu

(Pass code protected, if set)

The following functions can be set and modified:-

Common alarm relay allocation	Can be set to operate if one of the following alarms activate:- Low water Pump fail Pump run time Pump activity high Sensor error
Common alarm relay operation	Allows the relay to operate either as normally open or normally closed.
Pump Exercise	Allows the Pump Exercise function to be turned off or on, the default is on. Read Section 9.12 before turning off
Modbus address	Sets the Modbus address
Modbus enable	Allows the Modbus communication function to be turned on, default is off.
Run time limit	Sets the maximum time a pump can run before the pump run time alarm is activated. Set in increments of 10 minutes up to 60 minutes maximum. Disabled when the System fill option is turned on.
Passcode change	Sets a 4 digit passcode, defaults to 0000 (off). Can be user set to limit access to Setting, Advance setting and Test menus.
Pump run on delay	Sets the time the pump will continue to run after the system pressure (2) is reached on rising pressure. Adjustable from 3 to 120 seconds, pre-set to 10 seconds. Reducing this time will improve the accuracy of the pressure setting on lower volume systems
Pump start delay	Sets the time delay in starting the pump after system pressure - differential pressure (3) is reached on falling pressure. Adjustable from 3 to 120 seconds, pre-set to 3 seconds. Increasing this time will reduce unwanted CORE Midi operation during rapid system pressure fluctuations (circulator pump starts)

Cont ...

8.20 Test menu

(Pass code protected, if set)

The following functions can be set and modified:-

Pump test	Forces pump 1 (LH) or 2 (RH) to run for 5-10 seconds to enable operation of the pump to be confirmed.
System fill volume	Monitors the volume of water pumped into the system since it was last reset. Displayed in cubic metres (1m ³ = 1000 litres). Can be user reset.
Fill rate	Monitors the rate at which water is flowing into the system and is displayed as a real time flow rate (l/min).
Power interrupt log	Monitors how long the electrical power has been applied to the CORE Midi. Resets when power is removed or during a power cut. No user input.
Controller info	Displays software revision and pump set up. No user input.
Alarm log	Displays the last 10 alarm events. Can be user reset.
Pump run time log	Displays how long each pump has run. Can be user reset
Pump activity log	Displays which pump has run and how long it ran for. Can be user reset.

8.21 Pre-set values

The CORE Midi will be delivered with the following pre-set values:-

8.22 Setting menu

Set Pressure	2 bar
Differential	0.2 bar
Hi Alarm	2.5 bar
Lo Alarm	1.3 bar
System fill	off
Run activity high	1000

8.23 Advanced setting menu

Relay allocation	Pump fail
Relay operation	normally open
Pass code	0000 (not active)
Run time limit	10 minutes
Pump run on delay	10 seconds
Pump start delay	3 seconds

Cont ...

8.24 Controller menu diagram

17 Sept 2019

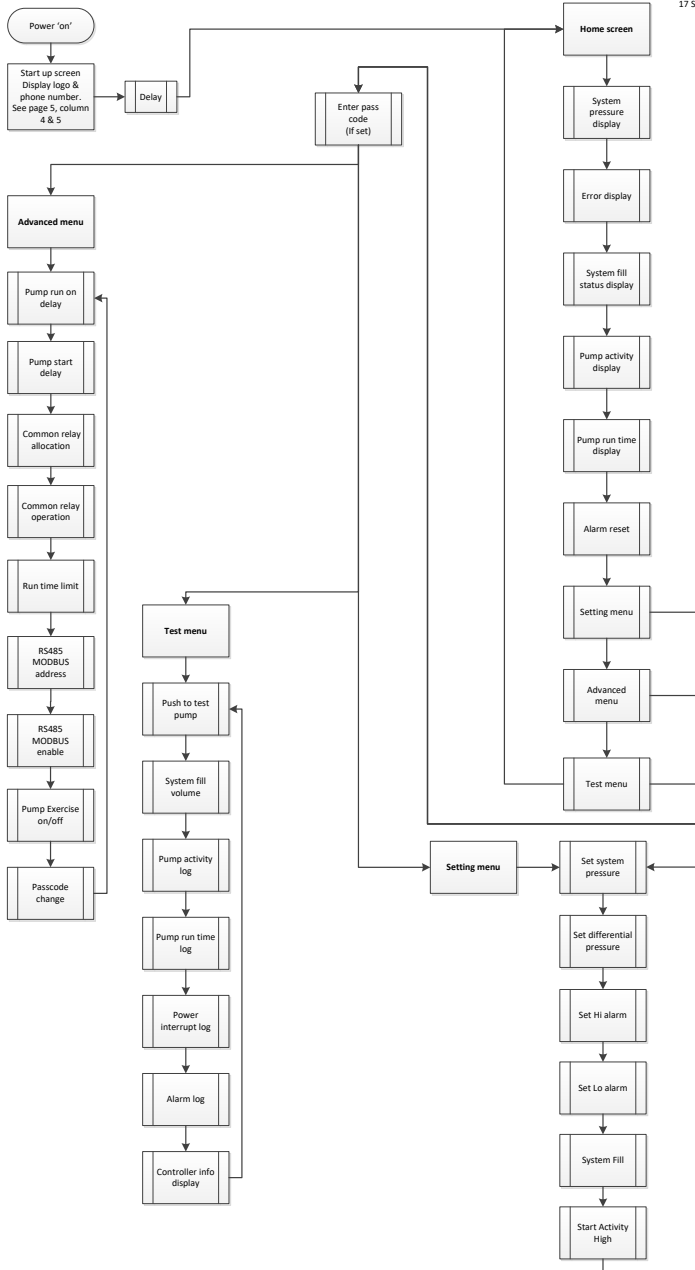

Fig. 22

8.25 Common alarm relay set-up:

The Common alarm relay (relay 3, Fig. 25) can be configured via the Advanced setting menu to activate when one of the following alarms are displayed on the screen:

Hi pressure	Pressure above the Hi pressure alarm (1)
Lo pressure	Pressure below the Lo pressure alarm (4)
Low water level	Low water level is seen by the sensor in the tank.
Pump fail	A system pressure increase is not achieved in a 5 minute period.
Pump run time high	A pump has run for longer than the set Pump run time value, 10 to 60 minutes without stopping.
Pump activity high	A pump has started more than the Start Activity high value in 24 hours.
Sensor fail	The sensor input is above or below the normal input range.

This will allow remote monitoring of an alarm to help fault find or monitor the system condition.

The Common alarm relay can also be configured via the Advanced setting menu to be open circuit (NO) or closed circuit (NC) when the alarm is active allowing the output signal to be changed

8.26 Hydraulic commissioning:

- Ensure both inlet and outlet hydraulic connections are made using the supplied rubber sealing washer and are watertight.
- Turn on water supply to CORE Midi – Check for leakage and operation of fill valve.
- Allow the tank to fill and water level to stabilise. Adjust the float of the fill valve to set the water level if needed.
- Bleed pumps by undoing the slot head bleed screw on the pump body by $\frac{1}{2}$ a turn until water can be seen to flow out. **Nip up, do not over tighten.**
- Close isolation valve on the outlet of the CORE Midi.
- Turn the electrical supply **ON** to the CORE Midi. The Stuart Turner start up logo will be displayed and then the Home screen will be displayed.
- The CORE Midi will run briefly and then turn off after a pre-set run on time. Due to the small size of the isolated system the CORE Midi will signal a Hi pressure error and the red error light will illuminate on the front of the CORE Midi, this is normal.
- Open the isolation valve on the outlet of the CORE Midi and the CORE Midi will run and start to fill the system.

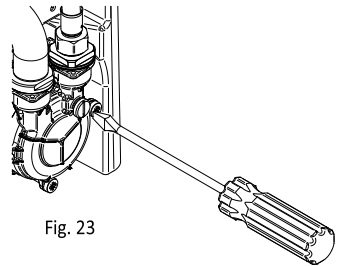

Fig. 23

8.27 **For further technical support:** Phone the Technical Helpline on +44 (0) 1785 218 206. Our staff are trained to help and advise you over the phone.

9 OPERATION

9.11 Normal operation:

The 'Home' screen will display the status of the tank water level, system pressure and if any pump is running. Pressing the return key (D) will get back to this screen.

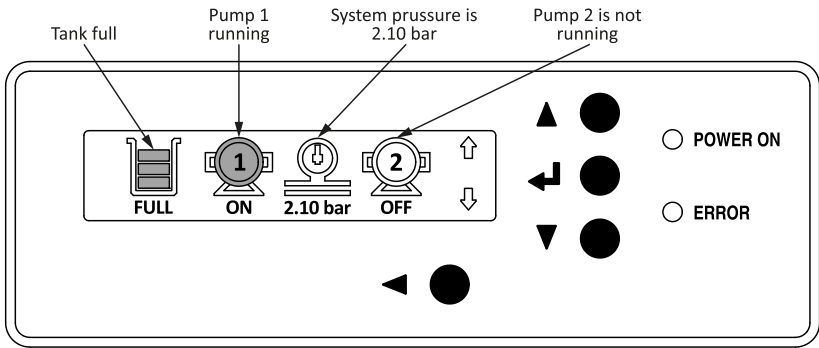

Fig. 24

A green 'Power on' light will be displayed on the front of the CORE Midi.

More detailed information is available by scrolling up or down to display:-

System pressure

System errors i.e. pump fail, low or high pressure or none.

System fill status on or off

Pump activity log

Last pump run

Alarm reset

Settings menu (access to more functions)

Advanced setting menu (access to more functions)

Test menu (access to more functions)

During normal operation the CORE Midi will monitor the system pressure and re-pressurise the system if the system pressure drops below the system pressure – differential pressure. See Fig. 20.

Example: System pressure 2 bar, differential pressure 0.5 bar, pump will start to re-pressurise system at 1.5 bar system pressure and stop at a system pressure of 2 bar. During the normal filling operation of the CORE Midi the pressure displayed on the screen may be shown slightly higher than the set pressure whilst the pump is running. As soon as the pump stops this displayed reading will settle back to the actual system pressure. During the normal operation of the pressurised system, the system pressure will fluctuate due to expansion and contraction of the water as the system temperature changes.

When setting the differential pressure and the Hi and Lo alarms please ensure that the normal system pressure fluctuations are below the Hi pressure alarm set pressure and above the differential pressure. If this is not done the CORE Midi will try to compensate for the pressure change causing an over pressure within the system or alarms being triggered.

9.12 **Pump exercise function:** If the pumps do not need to operate for more than a week, both pumps will start for 3-5 seconds to avoid the pump(s) from seizing due to inactivity. The CORE Midi is supplied with the Pump Exercise function enabled, but the function can be turned off if the brief running of the pump(s) causes the system pressure to increase over a prolonged period of time resulting in a system over pressure. If this function has been set to 'off' it is recommended that the pump(s) are manually operated monthly for a few seconds via the Test Menu and the system pressure adjusted accordingly afterwards to reduce the likelihood that the pumps will seize.

9.13 **Fault codes:**

If there is a system fault, a red light will be displayed on the front of the CORE Midi. If the fault/alarm is cleared the red light will go out.

The current fault will be displayed on the screen and logged in the alarm log (last 10 alarms).

10 MAINTENANCE

10.11 Routine maintenance & service checks:

Every 6 & 12 months (see Section 14 - service log) the CORE Midi should be inspected for:-

- Damage to the electrical supply cable.
- Damage to the inlet and outlet flexible hoses.
- Leakage from the CORE Midi or the connecting pipework.
- Controller log check; fault codes, pump run times, etc..
- Test unit operation.
- Float valve check.
- Level probe check.
- Water condition check.
- Expansion vessel pre-charge check.

10.12 Wiring diagram

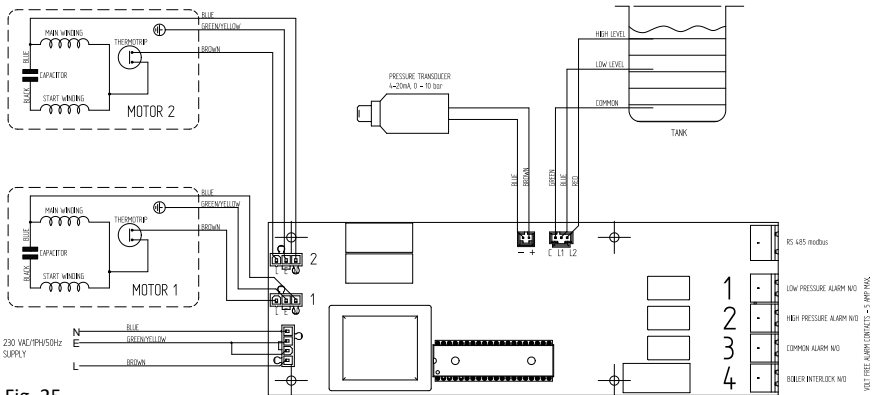

Fig. 25

There are no user servicable wiring or components inside the controller assembly.

DO NOT remove the retaining screws or the membrane cover over the display.

10.13 Long term isolation and restart procedure

If the system is to be shut down for an extended period of time due to maintenance or system modifications being carried out to the system the following steps must be taken.

1. Isolate mains inlet water from the CORE Midi.
2. Isolate the CORE Midi from the system and vent excess pressure to drain.
3. Run the CORE Midi to pump excess water from the tank to drain.
4. Isolate the electrical supply from the CORE Midi.
5. Remove the vent screws on the front of the pumps and allow excess water to drain. Replace vent screws. See section 8.26.
6. **Ensure the CORE Midi cannot freeze.** Damage **will** occur to the pumps if this is allowed to happen.
7. Cover with plastic sheet or cardboard if work is to be conducted close to the CORE Midi.

10.14 Restart

To ensure the CORE Midi is in good working order after a prolonged period of maintenance the following steps should be taken.

1. Inspect the CORE Midi for signs of damage.
2. Check CORE Midi tank for debris, remove debris and clean tank if needed. Debris may cause damage to the pumps if it is allowed to be drawn in.
3. Check pressure vessel pre charge pressures before the system pressure is increased.
4. Open the mains water isolating valve allowing the CORE Midi tank to fill, and ensure the fill valve is operating correctly and maintaining the correct water level.
5. Check for signs of leakage.
6. Open the drain valve on the outlet of the CORE Midi.
7. Turn on the mains electrical power and ensure both (if fitted) pumps can run (use test pump option if needed) and are pumping water to drain.
8. Close the drain valve and allow the CORE Midi to build pressure; the CORE Midi should turn off as the isolation valve to the system is closed.
9. Open the CORE Midi outlet isolation valve and monitor the CORE Midi to ensure there is no leaks as the system pressure increases.
10. Check all the pre set values on the CORE Midi to ensure they are still suitable for the system (after maintenance/modification)

11 ENVIRONMENT PROTECTION

Your appliance contains valuable materials which can be recovered or recycled.

At the end of the products' useful life, please leave it at an appropriate local civic waste collection point.

12 TECHNICAL SPECIFICATION

Pump Model		CORE Midi135	CORE Midi235	CORE Midi150	CORE Midi250
General	Warranty	2 year			
	Approvals	UKCA, CE			
Features	System capacity	Up to 300,000 litres			
	Mounting	Wall or floor mount			
	Pump control system	✓	✓	✓	✓
	Intelligent control interface	✓	✓	✓	✓
	System fill mode	✓	✓	✓	✓
	Dry run protection	✓	✓	✓	✓
	Typical noise	60 dB(A)	60 dB(A)	62 dB(A)	62 dB(A)
Materials	Break tank	Polyethylene			
	Front cover	Acrylic capped ABS			
Performance	Maximum fill pressure	3.5 bar (350 kPa)		4.1 bar (410 kPa)	
	Maximum flow	17 l/min		20 l/min	
	Maximum inlet pressure - tank fill valve	7 bar (700 kPa)			
	Maximum working pressure	6 bar			
	Ambient air temperature	Min 4°C / Max 40°C			
	Relative humidity	95% non-condensing			
	Min./Max. water temperature	Min 4°C / Max 23°C			
Water tank	Usable water capacity	8 litres			
	Inlet valve and fill rate	Torbeck (side entry) 12 l/min			
	Fluid category	CAT 5 (type AB air gap with weir)			
Connections	Cold water inlet and outlet	15 mm compression x 600 mm flexible hose			
	Overflow	G ¾ (19 - 23 mm diameter pipe compression fitting)			
Pump	Number of pumps	1	2	1	2
	Pump mode	Duty	Duty-standby	Duty	Duty-standby
	Pump type / head / impeller	Peripheral / brass / brass			
	Motor type	Induction (thermal trip, auto reset)			
	Duty rating	Continuous (S1)			
Electrical	Power supply (Vac/Ph/Hz)	230/1/50			
	Power consumption - P1	380 Watts		545 Watts	
	Current - full load	1.7 Amps		2.4 Amps	
	Fuse rating	5 Amps			
	Power cable length	1.5 metres (pre-wired)			
	Alarm output	Multiple			
Physical	Enclosure protection	IPX4			
	Width	415 mm			
	Depth	270 mm			
	Height	504 mm			
	Weight - including fittings	13.4 Kg	19.4 Kg	13.4 Kg	19.4 Kg
	Weight - filled	23.4 Kg	29.4 Kg	23.4 Kg	29.4 Kg

Smith Brothers Stores Ltd reserve the right to amend the specification without notice.

12.11 **Noise:** The equivalent continuous A-weighted sound pressure level at a distance of 1 metre from the pump does not exceed 70 dB(A).

13 TROUBLE SHOOTING GUIDE

Symptoms	Error Code	Probable Cause	Recommended Action
No power	Blank screen	No power to CORE Midi Internal re-settable fuse tripped	Check power supply / fuse. Remove mains power from the CORE Midi for 20 seconds, re-apply the power.
Pump(s) not starting	Low water Pump run fail Pump run fail Sensor error	No power to CORE Midi Low water in tank System pressure = set pressure Pump seized System pressure set too high Pressure sensor fault	Ensure the green light is on the front of the CORE Midi, check fuse. Depress float valve to verify water is filling tank, check water level and supply. CORE Midi functioning correctly. Check the set system pressure. Force the pumps to run using the pump test function. Clear error. System set pressure is set higher than the pump performance capability, reduce set pressure. Ensure you have purchased the correct CORE Midi for the system pressure required. Remove pressure from the CORE Midi outlet and verify the displayed pressure is 0 bar. Error will be displayed if the sensor signal is outside parameters. (Replace sensor – call Smith Brothers Stores Ltd).
Pump(s) will not stop	Sensor error	System pressure set too high Pressure sensor fault	System set pressure is set higher than the pump performance capability, reduce set pressure. Ensure you have purchased the correct CORE Midi for the system pressure required. Remove pressure from the CORE Midi outlet and verify the displayed pressure is 0 bar. Error will be displayed if the sensor signal is outside parameters. (Replace sensor – call Smith Brothers Stores Ltd).
Low pressure alarm triggered	Low pressure Sensor error	Leak in system. Low pressure alarm set too high. Pressure sensor fault	Check system for leaks. Check pump activity in logs. Check for leaking pressure relief valve. Reduce Low press alarm pressure. Check system pressure range during normal operation. Remove pressure from the CORE Midi outlet and verify the displayed pressure is 0 bar. Error will be displayed if the sensor signal is outside parameters. (Replace sensor – call Smith Brothers Stores Ltd).
High pressure alarm triggered	High pressure Sensor error	System pressure too high Pressure sensor fault	Check system operation. Increase High pressure alarm set pressure. Remove pressure from the CORE Midi outlet and verify the displayed pressure is 0 bar. Error will be displayed if the sensor signal is outside parameters. (Replace sensor – call Smith Brothers Stores Ltd).
Pump run time alarm activated. Pump running for longer than set time	Pump run time alarm	Pump filling system Leak in system	Activate system fill option to suppress alarm for 24 hours. Check system for leakage. Monitor using system fill volume log, reset if needed. Increase pump run time limit.
Activity high alarm activated. Pump starting more than set value	Activity High alarm	Pump filling system Leak in system Activity High alarm number too low	Activate system fill option to suppress alarm for 24 hours. Check system for leakage. Monitor using system fill volume log, reset if needed. Increase the Activity High alarm value.
Sensor failure error	Sensor error	Pressure sensor outside specification	Remove pressure from the CORE Midi outlet and verify the displayed pressure is 0 bar. Error will be displayed if the sensor signal is outside parameters. (Replace sensor – call Smith Brothers Stores Ltd).
Low water error	Low water	Loss of water supply to CORE Water level set too low	Depress float valve to verify water is filling tank and check water level and supply. Adjust water level by turning float, ensure upper-level probe is in contact with water when the fill valve is turned off. Check water level prior to leaving unattended.
Water overflowing warning pipe or weir		Water level too high Pump NRV leaking	Check function of the fill valve, replace or adjust if needed. Isolate CORE Midi from system and mains water and replace non-return valve and holder.

Cont ...

14 PRODUCT LOG

14.11 Customer details

Customer/company name	
Site address	
Date	

14.12 Equipment details

System volume m ³	
Expansion vessel(s) fitted & pre-charge pressure	
Boiler(s) fitted	

14.13 Commissioning record

Date commissioned	
Company	
Engineer	
System set pressure	
Differential pressure	
Hi alarm set pressure	
Lo alarm set pressure	

14.14 Service Log

Service No. 1			
Date			
Engineer name			
Company name			
Tel. No			
System pressure bar			
Differential pressure bar			
Check		6 months	12 months
Condition of wiring		✓	✓
Condition of hoses		✓	✓
Evidence of leakage		✓	✓
Controller fault codes		✓	✓
Test pump operation		✓	✓
Float valve operation		x	✓
Level probe operation		x	✓
Water condition		x	✓
Exp. vessel pre-charge		x	✓
Comments			

Cont ...

Service No. 2			
Date			
Engineer name			
Company name			
Tel. No			
System pressure bar			
Differential pressure bar			
Check		6 months	12 months
Condition of wiring		✓	✓
Condition of hoses		✓	✓
Evidence of leakage		✓	✓
Controller fault codes		✓	✓
Test pump operation		✓	✓
Float valve operation		x	✓
Level probe operation		x	✓
Water condition		x	✓
Exp. vessel pre-charge		x	✓
Comments			

Service No. 3			
Date			
Engineer name			
Company name			
Tel. No			
System pressure bar			
Differential pressure bar			
Check		6 months	12 months
Condition of wiring		✓	✓
Condition of hoses		✓	✓
Evidence of leakage		✓	✓
Controller fault codes		✓	✓
Test pump operation		✓	✓
Float valve operation		x	✓
Level probe operation		x	✓
Water condition		x	✓
Exp. vessel pre-charge		x	✓
Comments			

Cont ...

Service No. 4			
Date			
Engineer name			
Company name			
Tel. No			
System pressure bar			
Differential pressure bar			
Check		6 months	12 months
Condition of wiring		✓	✓
Condition of hoses		✓	✓
Evidence of leakage		✓	✓
Controller fault codes		✓	✓
Test pump operation		✓	✓
Float valve operation		x	✓
Level probe operation		x	✓
Water condition		x	✓
Exp. vessel pre-charge		x	✓
Comments			

Service No. 5			
Date			
Engineer name			
Company name			
Tel. No			
System pressure bar			
Differential pressure bar			
Check		6 months	12 months
Condition of wiring		✓	✓
Condition of hoses		✓	✓
Evidence of leakage		✓	✓
Controller fault codes		✓	✓
Test pump operation		✓	✓
Float valve operation		x	✓
Level probe operation		x	✓
Water condition		x	✓
Exp. vessel pre-charge		x	✓
Comments			

Cont ...

15 THE WARRANTY

Congratulations on purchasing a CORE product.

We are confident this product will provide many years of trouble free service as all our products are manufactured to the very highest standard.

The Smith Brothers Stores CORE Midi is warranted to be free from defects in materials or workmanship for 2 years from the date of purchase.

Within the warranty period we will repair, free of charge, any defects in the product resulting from faults in material or workmanship, repairing or exchanging the whole unit as we may reasonably decide.

Not covered by this warranty: Damage arising from incorrect installation, improper use, unauthorised repair, normal wear and tear and defects which have a negligible effect on the value or operation of the product.

Reasonable evidence must be supplied that the product has been purchased within the warranty term prior to the date of claim (such as proof of purchase or the product serial number).

This warranty is in addition to your statutory rights as a consumer. If you are in any doubt as to these rights, please contact your local Trading Standards Department.

In the event of a claim please telephone '**Technical Helpline**' with proof of purchase and product serial number.

+44 (0) 1785 218 206

You should obtain appropriate insurance cover for any loss or damage which is not covered by Smith Brothers Stores Ltd in this provision.

Please record here for your records.

TYPE NO.	SERIAL NO.	DATE PURCHASED



DECLARATION OF CONFORMITY



Supply of Machinery Regulations - 2008

EN ISO 12100:2010, EN 809:1998
+A1:2009/AC:2010

Electrical Equipment Regulations - 2016

EN 60335-1:2012/A2:2019, EN
60335-2-41:2003/A2:2010

EMC Regulations - 2016

EN 61000-3-2, EN
61000-3-3, EN 61000-4-2, EN 61000-4-3,
EN 61000-4-4, EN 61000-4-5, EN
61000-4-6, EN 61000-4-11, EN 61000-6-1,
EN 61000-6-3

EMF Regulations - 2016

EN 62233:2008

RoHS Regulations - 2012

EN IEC 63000:2018

Machinery Directive - 2006/42/EC

EN ISO 12100:2010, EN 809:1998+A1:2009/
AC:2010

Low Voltage Directive - 2014/35/EC

EN 60335-1:2012/A2:2019, EN
60335-2-41:2003/A2:2010

EMC Directive - 2014/30/EU

EN 61000-3-2, EN
61000-3-3, EN 61000-4-2, EN 61000-4-3, EN
61000-4-4, EN 61000-4-5, EN 61000-4-6, EN
61000-4-11, EN 61000-6-1, EN 61000-6-3

EMF Directive - 1999/519/EC

EN 62233:2008

RoHS Directive - 2011/65/EU

EN IEC 63000:2018

WEEE Directive - 2012/19/EU

IT IS HEREBY CERTIFIED THAT THE PRESSURISATION UNIT AS SERIAL NUMBER BELOW, COMPLIES WITH THE ESSENTIAL REQUIREMENTS OF THE ABOVE STATUTORY REGULATIONS & E.U. DIRECTIVES.



SMITH BROTHERS STORES LIMITED,
UNIT V2 WINCHESTER AVENUE BLABY,
LEICESTER. LE8 4GZ

RESPONSIBLE PERSON AND MANUFACTURER

Signed *Andrew Raine*
ANDREW RAINE | SUPPLY CHAIN DIRECTOR

EU AUTHORISED REPRESENTATIVE

ARC (AUTHORISED REP COMPLIANCE)
GND FLOOR, 71 LOWER BAGGOT
STREET, DUBLIN,
D02 P593, IRELAND.

Smith Brothers Stores Limited reserves the right to amend specifications without notice.
CORE is a registered trademark owned by Smith Brother Stores Ltd
Registered Office, Unit V2 Winchester Avenue Blaby, Leicester. LE8 4GZ

