

CORE 140

Ductile Iron Butterfly Valve Lugged & Tapped

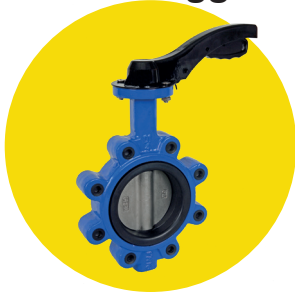

Features

- Flanged mounting PN16 only
- BS5155 (BS EN 593)
- ISO 5211 direct mount
- Lockable handle
- Epoxy coat finish

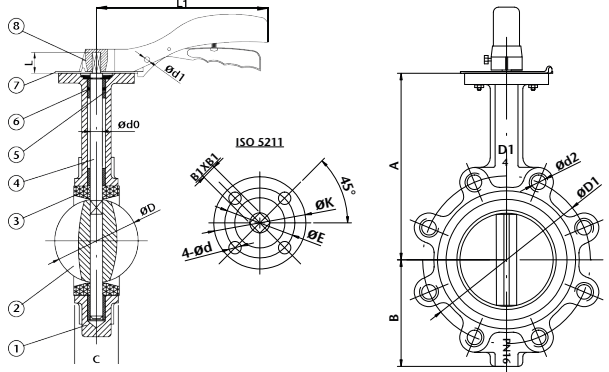

Technical data

Max pressure: 16 Bar

Working temp: -10°C to +110°C

DN	2"	2 1/2"	3"	4"	5"	6"	8"	10"	12"
A	140	150	158	176	190	211	235	265	305
B	80	89	95	114	127	139	175	203	242
C	42.0	44.7	45.2	52.0	54.4	55.8	60.6	65.6	76.9
D	52.9	64.5	78.8	104.0	123.3	155.1	202.5	250.5	301.5
D1	125	145	160	180	210	240	295	355	410
L	26	26	26	30	30	30	36	36	36
L1	170	170	170	215	215	215	352	352	352
d0	12.6	12.6	12.6	15.8	18.9	18.9	22.1	28.5	31.6
d1	6	6	6	6	6	6	6	6	6
d2	4x16	4x16	8x16	8x16	8x16	8x20	12x20	12x24	12x24
ISO 5211	F05	F05	F05	F07	F07	F07	F10	F10	F10
K	65	65	65	90	90	90	125	125	125
d	4x7	4x7	4x7	4x10	4x10	4x10	4x12	4x12	4x12
B1	9	9	9	11	14	14	17	22	22
Torque	15.1	17.2	23.1	39.8	61.9	102.0	192.0	323.0	490.0
Kv	90.97	191.44	360.93	892.66	995.29	1705.87	3182.92	4961.15	9252.07
Kgs	3.15	3.80	4.80	6.97	8.70	10.60	19.00	27.98	37.46

We strongly advise gearbox on all 8", 10" and 12" valves.

N. Part Name Materials

1	Body	Ductile Iron GGG40
2	Disc	Stainless Steel 316
3	Seat	EPDM
4	Stem	Stainless Steel 410
5	Bush	PTFE
6	O-Ring	EPDM
7	Indicator	Carbon Steel
8	Handle	Aluminium

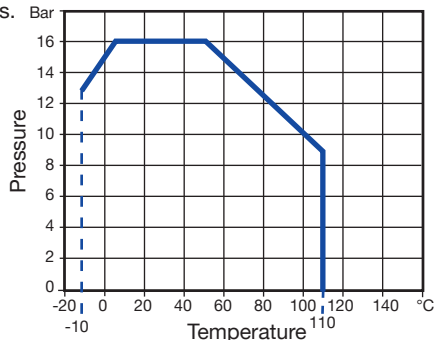

V3. Dimensions in mm

The information within this document is believed to be correct at the time of publication; however, the document is for guideline use only. For complete accuracy, always check the product with an SBS representative. Missing information was either not available or disclosed. It is your responsibility that any product meets the necessary requirements. Any reliance placed upon this information will be totally at the user's risk.