

CORE 630

PN20 Brass Gate Valve



Features

- Screwed BSP Taper (ISO 7/1)
- Brass body & wedge
- BS5154

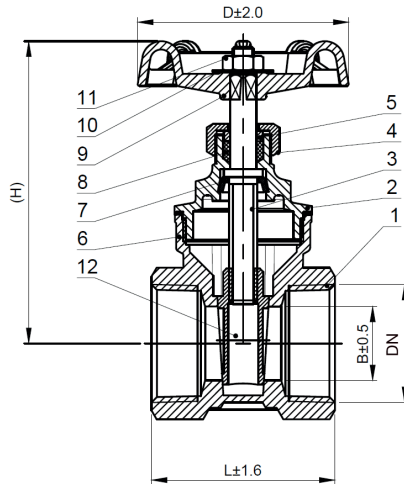

Technical data

Max pressure: 20 Bar

Working temp: -20°C to +170°C

DN	1/2"	3/4"	1"	1 1/4"	1 1/2"	2"	2 1/2"	3"	4"
L	43	46	52	65	66	82.5	88	92	110
H	69.7	75	84.5	99	109.5	130.5	163	189	232.5
D	53	53	60	72	72	80	100	108	128
B	13	17	21	27	34	45	56	68	90
Kv	8.4	15.2	22.1	39.8	63.1	142.0			
Kgs	0.25	0.33	0.46	0.82	1.10	1.60	2.62	3.41	6.05

N.	Part Name	Materials
1	Body	Brass HPb58-2
2	Bonnet	Brass HPb58-2
3	Stem	Brass CW617N
4	Packing Nut	Brass HPb58-2
5	Washer Ring	Brass HPb58-2
6	Gasket	PTFE
7	Lock Ring	Brass HPb58-2
8	Stem Packing	PTFE
9	Hand Wheel	Cast Iron HT200
10	Nameplate	Steel L2
11	Hex Nut	Steel Q235A
12	Disc	Brass HPb58-2

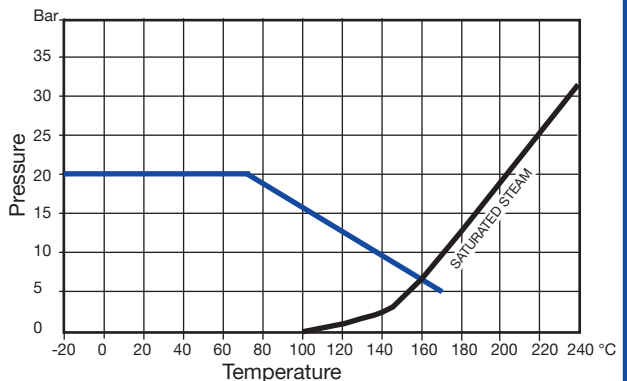

V1. Dimensions in mm

The information within this document is believed to be correct at the time of publication; however, the document is for guideline use only. For complete accuracy, always check the product with an SBS representative. Missing information was either not available or disclosed. It is your responsibility that any product meets the necessary requirements. Any reliance placed upon this information will be totally at the user's risk.