

CORE TMV TYPE 3

INSTALLATION Continued

- Consideration must be made for the possibility of multiple/simultaneous demands being made on the supply system whilst the CORE 5213 valves are in use, all practical precautions must be made to ensure that the valve is not affected. Failure to make provision within the pipe sizing etc. will affect the performance of the valve.
- The supply system to which the CORE 5213 TMV valves are to be installed into must be thoroughly flushed and cleaned to remove any debris, which may have accumulated during the installation. Failure to remove any debris will affect the performance and the manufacturer's warranty of the product. Independent filters and isolation valves must be fitted in conjunction with the valve, as close as practically possible to the water supply inlets of the thermostatic mixing valve. In areas that are subject to aggressive water, provision must be made to treat the water supply prior to the supply entering any CORE product.
- The maximum flow rate of the valve will only be achieved when the supply conditions are achieved as quoted within the Technical Specification, with a flow condition under 1 bar differential pressure.
- CORE 5213 valves have been designed to ensure that the valve can be installed in any position whether vertical or horizontal, it can be surface mounted or within a supply duct. It is essential that the access to the valve is not obstructed for any future maintenance that may be required to the valve or associated fittings.
- We recommend that CORE 5213 thermostatic mixing valves are installed as close as practically possible to the outlet, which it is serving. In this situation attention must be paid to the maximum distance of pipe work from the mixed water outlet of the valve to any terminal fitting. NHS/DoH HTM 04-01 Part A guidelines recommend a maximum distance of 2 metres from the outlet of the mixing valve to the terminal fitting, which the mixing valve is to serve.
- The hot and cold water supplies must be connected to the valve strictly in accordance with the indications on the body of the valve i.e. hot water supply to the hot port of the valve.
- In a situation where one or both of the water supplies are excessive, it is possible to fit a pressure reducing valve to reduce the pressure(s) to within the limits as quoted previously.
- Any thermostatic mixing valve must be fitted with a back flow prevention device, such as check valves to prevent the cross contamination of supplies. The CORE 5213 valves are complete with integral insert check valves and strainers. However if required, additional WRAS approved backflow prevention devices should be positioned as close as practically possible to the water supply inlets of the thermostatic mixing valve. A complete range of backflow prevention devices are available to complement this product.
- Y Pattern strainers and full-bore isolation valves must be installed in conjunction with the CORE 5213 fail-safe thermostatic mixing valves as close as is practically possible to the location of the valve. Alternatively the use of the thermostatic mixing valve with the MX end pieces removes the need for additional filters and isolation valves.
- It is essential that the CORE 5213 thermostatic mixing valves should not be installed in situations where there is a possibility of the valve being deprived of water or where demands for water are greater than the actual stored supplies.

INSTALLATION Continued

- To ensure that the performance levels of the CORE 5213 thermostatic mixing valves are maintained (in the event of cold water failure), the temperature of the hot water supply at the point of entry to the valves must be a minimum of 10°C above the commissioned mixed water discharge temperature.
- The CORE 5213 thermostatic mixing valves must not be subject to any extreme temperature variations either during the installation or under normal operating conditions.

METHOD of ADJUSTING the MIXED WATER TEMPERATURE

- IMPORTANT** - The following instructions must be read and understood prior to the adjustment of the mixed water outlet temperature and this action MUST only be carried out by a suitably qualified person.
- Remove the cap from the valve.
 - Remove the temperature locking from the spindle using a suitably sized spanner.
 - Open the outlet to which the mixing valve is supplying and establish a stable flow and temperature.
 - Using a calibrated thermometer place the sensing part of the thermometer probe under the flowing water.
 - Using a suitably sized spanner turn the temperature adjustment spindle anti-clockwise to increase the mixed water temperature or clockwise to reduce the mixed water temperature – at all times ensuring the probe of the thermometer is under the flowing water.
 - Once the desired temperature is reached – replace the temperature locking ring on the spindle and re fit the cap of the valve.
 - The temperature at the terminal fitting must never exceed 46°C.

COMMISSIONING

- IMPORTANT** - The following instructions must be read and understood prior to the commissioning of the CORE 5213 fail-safe thermostatic mixing valves. If under any circumstances there are aspects to the installation / system which do not comply with the specification laid down, the valve MUST NOT be put into operation until the system / installation complies with our specification. However if all these conditions are met, proceed to set the temperature as follows:
- Ensure that the system is thoroughly cleaned and free from any debris prior to commissioning the CORE fail-safe thermostatic mixing valves.
 - Commissioning the temperatures must be carried out using a suitably calibrated thermometer - preferably a digital thermometer.

Table 1

Application	Recommended Set Mixed Water Temp
Wash Hand Basin	41°C
Shower	41°C
Bidet	38°C
Bath Fill	44°C

COMMISSIONING Continued

- Note 1:** The maximum mixed water outlet temperature i.e. 41°C max, 44°C etc. being delivered during normal use can deviate by 2°C above the recommended set outlet temperatures detailed in the table.
- Note 2:** For washbasins, washing under running water is assumed.
- Note 3:** Bath fill temperatures of more than 44°C should only be available when the bather is always under the supervision of a competent person (e.g. nurse or care assistant).
- Note 4:** The CORE 5213 thermostatic mixing valve is capable of satisfying all the individual applications and should be re-set on-site to meet the designated application.

- In the absence of other temperatures being specified, we recommend the outlet temperatures quoted in Table 1.
- Each valve must be commissioned taking into consideration any fluctuations, which may occur within the system due to simultaneous demands. It is advisable that any outlets which are connected to the same supply as the mixing valve are opened during the setting of the mixed water temperature. During commissioning it is advisable to ensure that the water temperatures are established before any attempt to commission.
- Once the supply temperatures are stable and the normal operating conditions are established, the valve can be commissioned. The temperature setting can be adjusted by removing the cap and locking ring from the valve body and adjusting the temperature adjustment spindle. We suggest that the following sequence is followed when commissioning the valve:
 - Set the mixed water temperature to the required temperature.
 - Measure and record the temperature of the hot and cold water supplies at the connection to the valve.
 - Measure and record the temperature of the water discharging from the valve from the largest and smallest draw off point.
 - Isolate the cold water supply to the valve and monitor the mixed water temperature.
 - Measure and record the maximum mixed water temperature and the final temperature. The final temperature found during the test should not exceed the values quoted in Table 2.
 - Record all the equipment used during the commissioning.

Table 2

Application	Maximum Set Mixed Water Temperature
Wash Hand Basin	43°C
Shower	43°C
Bidet	40°C
Bath Fill	46°C

- Note:** Bath fill temperatures of more than 44°C should only be available when the bather is always under the supervision of a competent person (e.g. nurse or care assistant).
- Once the desired temperature is established remove the cap and secure the temperature spindle with the locking ring and replace the cap into its original position to prevent tampering by unauthorized persons.

COMMISSIONING Continued

- Ensure that the application, in which the valve will be used, is appropriate for the approved designation. The above information must be recorded and updated on every occasion when any work is carried out on the valve.

MAINTENANCE

- To ensure that the CORE 5213 valves maintain a high level of protection, we advise the following in service testing is conducted (the same equipment used to commission the valve initially must be used in the following tasks).
- After a period of between 6 and 8 weeks from commissioning carry out the following:
 - Record the temperature of the hot and cold water supplies.
 - Record the temperature of the mixed water at the largest draw off flow rate.
 - Record the temperature of the mixed water at the smallest draw off outlet temperature.
 - If the mixed water temperature has changed significantly from the previous test results (e.g. >1°C), record the change and before resetting the mixed water temperature check that:
 - All the strainers are clean (see Installation 3).
 - All the check valves are in good working order (see Installation 9).
 - The isolation valves are fully open.
 - If the mixed water temperatures are acceptable, carry out the following:
 - Record the temperature of the hot and cold water supplies
 - Record the temperature of the mixed water at the largest draw off flow rate
 - Record the temperature of the mixed water at the smallest draw off flow rate
 - Isolate the cold water supply to the mixing valve and monitor the mixed water temperature
 - Record the maximum temperature achieved as a result of (3.4) and the final temperature (the final temperature should not exceed the values quoted in table 2)
 - Record the equipment used during these tests
 - If the mixed water temperature is greater than the values quoted in table 2 or the maximum and differs from the corresponding values from previous test results by more than 2°C, the valve must be serviced.
 - After a period of between 12 to 15 weeks from commissioning, carry out the sequence of tests as described in Maintenance sections 1, 2, 3 and 4.
 - Dependant upon the results obtained from the first two series of tests; there are a number of possible outcomes:
 - If no significant change in the mixed water temperatures (e.g. ≤ 1°C) is recorded between commissioning and maintenance sections 1 or between commissioning and Maintenance sections 5, the next in service testing should be carried out at a period of 24 to 28 weeks after initial commissioning.
 - If a small change (e.g. 1 to 2°C) in the mixed water temperature is recorded in only one of these periods, necessitating adjustment of the mixed water temperature, then the next in service test can be deferred to 24 to 28 weeks after commissioning.
 - If small changes (e.g. 1 to 2°C) in the mixed water temperature are recorded in both of these periods, necessitating adjustment of the mixed water temperature, then the next in service test can be deferred to 18 to 21 weeks after commissioning.

MAINTENANCE Continued

- If significant changes (e.g. > 2°C) in the mixed water temperature are recorded in both of these periods necessitating service work, then the next in service test should be carried out at 18 to 21 weeks after commissioning.
- The general principle to be observed after the first 2 or 3 in-service tests is that the intervals for future tests should be set to those which previous tests have shown can be achieved with no more than a small change in mixed water temperature.
- In all areas periodic maintenance of the valve and associated fittings i.e. strainers, check valves will ensure optimum performance levels are maintained.

SPARES

For component identification see page 16.

PROBLEM SOLVING

For resolving on site problems see below.

CORE TMV TYPE 2/3

PROBLEM SOLVING

The following details are supplied for on site queries, should you require any further assistance contact our Technical Department.

- Hot water at the cold tap**
 - Operation of the insert check valves is hindered, check the valve is seated correctly.
 - Check Valves not fitted.
 - Unbalanced hot/cold supply pressure.
- Fluctuating mixed water temperature**
 - Erratic supply temperatures at the inlets of the valve.
 - Starvation of the water supplied at the inlets of the valve.
 - Incorrect commissioning of the valve.
- Erratic flow**
 - Insufficient water supplies.
 - Fluctuations in the supply pressures/temperatures.
 - Adverse effect created by other draw off points on the system.
- No flow/reduced flow from valve**
 - In line filters are blocked.
 - Insufficient supply pressure.
 - Debris obstructing valve operation.
 - Valve requires servicing (Servicing kits available on request).
- Valve does not fail safe when tested**
 - Installation not in accordance with our recommendations.
 - The minimum temperature differential not achieved.
 - Internal mechanism hindered by debris.

Full and detailed instructions are supplied with service kits and are available on request.

CORE TMV TYPE 2/3 FLOWRATES

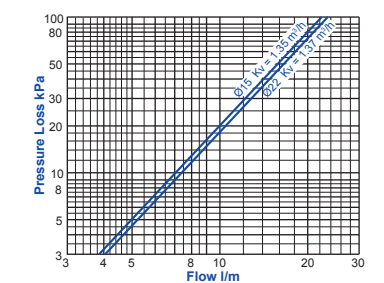

DIMENSIONS

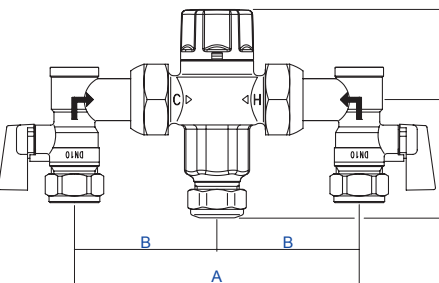
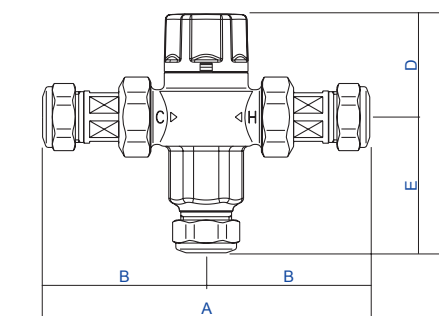

DIMENSIONS

A mm	B mm	C mm	D mm	E mm	WEIGHT kg
141	67.5	99	43	56	0.57
150	75	100	43	57	0.79
120	60	99	43	56	0.77
136	68	100	43	57	1.00

SPARES

A full range of spares are available for this product.

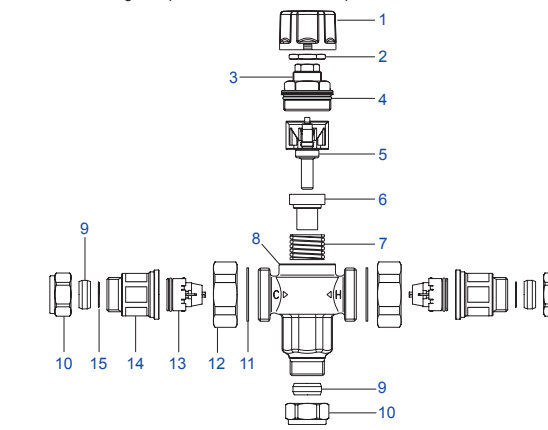

ITEM	COMPONENT	ITEM	COMPONENT
1	Cap	9	Olive
2	Temperature locking ring	10	Compression nut
3	Valve Head Assembly	11	Gasket
4	Head Assembly 'O' Ring	12	Union nut
5	Thermostatic Element	13	Check valve cartridge
6	Flow Conveyor	14	Inlet tail housing
7	Spring	15	Inlet tail filter
8	Valve body		



Please leave these instructions for the user

Installation & Maintenance Instructions



CORE is a registered trademark owned by Smith Brothers Stores Ltd.
Registered office: Unit V2 Winchester Avenue, Blaby, Leicester. LE8 4GZ

IOM 198 V1 15-11-23

CORE TMV TYPE 2

The following information is required for use when the CORE 5213 thermostatic mixing valves are used in TMV2 Applications under the requirements of BS EN 1111: 2017 "Sanitary tapware. Thermostatic Mixing Valve (PN 10). General Technical Specification" and BS EN 1287: 2017 "Sanitary tapware. Low pressure thermostatic mixing valves. General technical specifications"

INTRODUCTION

The CORE 5213 thermostatic mixing valves have been specifically designed and manufactured to meet the requirements of BS EN 1111: 2017 and BS EN 1287: 2017 and TMV2 Type 2 Scheme. The valves have been independently tested and approved by Kiwa Watertec as a TYPE 2 valve under the Kiwa Watertec TMV Type 2 scheme.

TMV Type 2 certified products comply with Building Regulations G3.

TECHNICAL SPECIFICATION/ CONDITIONS FOR USE TYPE 2 VALVES

	High Pressure BS EN 1111	Low Pressure BS EN1287
Max. Static Pressure	10 bar	10 bar
Flow Pressure, Hot & Cold	0.5 - 5 bar	0.1 - 1.0 bar
Hot Supply Temperature	55°C - 65°C	55°C - 65°C
Cold Supply Temperature	≤25°C	≤25°C
Temperature Stability	±2°C	±2°C
Min. Temp Differential (Mix to Hot) for fail-safe	10°C	10°C
Max. Pressure Inlet Differential	5:1	5:1

- NOTE:** i) Valves operating outside these conditions cannot be guaranteed by the Scheme to operate as Type 2 valves.
- ii) To ensure and maintain water quality system water supply temperature should be maintained within certain criteria. This criteria is laid out in a legal obligation document HSG247
- iii) HSG247 part 2, Cold water should be stored at and distributed at less than 20°C. Hot water should be stored at least at 60°C and be delivered at 50°C in less than 1 minute of the outlet device being activated.
- NB:** If the outlet device is a mixing valve, the temperature of the hot water 50°C, is measured at the hot water supply inlet to the mixing valve and not the mixing valve's outlet. TMV Type 2 mixing valves require a 55°C minimum hot supply.

APPROVALS

Kiwa Watertec Scheme Approval Number	Details Available on Request
WRAS Scheme Approval Number	Details Available on Request

DIMENSIONS

For dimensions see pages 15 and 16.

FLOWRATES

For Kv values and flowrate - pressure loss chart see page 15.

APPLICATION

The valves designation of use, LP if tested against BS EN 1287, HP if tested against BS EN 1111 and HP and LP if tested against both standards. The CORE 5213 thermostatic mixing valves have been independently tested by Kiwa Watertec and certified as meeting the requirements of the BS EN 1111: 2017 and BS EN 1287: 2017 under the TMV Type 2 Scheme as being suitable for use on the following designations.

	High Pressure (HP 0.5 to 5 bar)	Low Pressure (LP 0.1 to 1 bar)
Wash Hand Basin (W)	HP-W	LP -W
Shower (S)	HP-S	LP-S
Bidet (B)	HP-B	LP-B
Tub/Bath Fill*	HP-T	22mm model only

If a water supply is fed by gravity then the supply pressure should be verified to ensure the conditions of use are appropriate for the valve. The installation of thermostatic mixing valves must comply with the requirements of the Water Supply (Water Fittings) Regulations 1999.

RECOMMENDED OUTLET TEMPERATURES

The Kiwa Watertec TMV scheme recommends the following set maximum mixed water outlet temperatures for use in all premises and then verified by undertaking the cold water isolation test.

Application	Recommended Set Mixed Water Temp
Wash Hand Basin	41°C
Shower	41°C
Bidet	38°C
Bath Fill	44°C

- NOTE:** i) The maximum mixed water outlet temperature i.e. 41°C max, 44°C etc. being delivered during normal use can deviate by 2°C above the recommended set outlet temperatures detailed in the table..
- ii) The tub/bath fill temperature in the table is not a safe bathing temperature for adults or children, it is a value that allows for heat loss during tub/bath filling. The British Burns Association recommends 37 to 37.5°C as a comfortable bathing temperature for children. In premises covered by the Care Standards Act 2000, the maximum water outlet temperature is 43°C.
- iii) All temperature measuring equipment should be calibrated and appropriate for measurement.

INSTALLATION

IMPORTANT: - The following instructions must be read prior to the installation of the CORE 5213 thermostatic mixing valves, the installer should also be aware of their responsibility and duty of care to ensure that all aspects of the installation comply with all current regulations and legislation.

It has been brought to our attention that flushing through water systems using certain chemicals may wholly or partially remove the lubricant from the internal workings of the valve, which may adversely affect its performance. We recommend that following flushing the system with chemicals; valves are checked for correct operations.

- The installation of thermostatic mixing valves must comply with the requirements of the Water Supply (Water Fittings) Regulations' 1999 and Scottish Water Byelaws.
- The Thermostatic mixing valve must be installed in such a location that maintenance of the TMV using its isolating valves and that the commissioning and testing of the TMV can be undertaken.
- If isolation valves are not provided by the manufacturer, the fitting of isolation valves is required as close as is practicable to the water supply inlets of the thermostatic mixing valve.
- If strainers are not provided by the manufacturer, the fitting of strainers is recommended as close as is practicable to the water supply inlets of the thermostatic mixing valve.
- The temperature differential between the hot supply temperature and the maximum mixed water temperature is appropriate for the valve.
- Backflow prevention devices may be required to prevent contamination of the water supply from the downstream risk, see the Water Supply (Water Fittings) Regulations 1999, and Scottish Water Byelaws and the manufacturer's instructions.

- It is essential that before installing any CORE 5213 valves ensure that the supply conditions of the system to which the valve is intended to be fitted are checked to confirm compliance with the parameters as quoted within the Technical Specification and conditions on which the approval is granted i.e. verify supply temperatures, supply pressures, risk assessment.
- Consideration must be made for the possibility of multiple/simultaneous demands being made on the supply system whilst the CORE 5213 valves are in use, all practical precautions must be made to ensure that the valve is not affected. Failure to make provision within the pipe sizing etc. will affect the performance of the valve.
- The supply system to which the CORE 5213 valves are to be installed into must be thoroughly flushed and cleaned to remove any debris, which may have accumulated during the installation. Failure to remove any debris will affect the performance and the manufacturer's warranty of the product. Independent filters and isolation valves must be fitted in conjunction with the valve, as close as practically possible to the water supply inlets of the CORE 5213 thermostatic valve. In areas that are subject to aggressive water, provision must be made to treat the water supply prior to the supply entering any CORE product

INSTALLATION CONTINUED

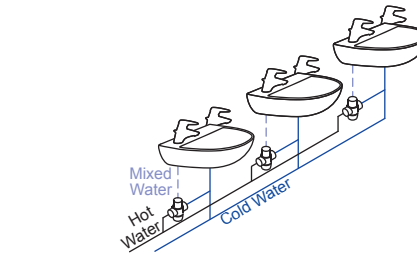

- CORE 5213 valves have been designed to ensure that the valve can be installed in any position whether vertical or horizontal, it can be surface mounted or within a supply duct. It is essential that the access to the valve is not obstructed for any future maintenance that may be required to the valve or associated fittings.
- We recommend that the CORE 5213 thermostatic mixing valves be installed as close as practically possible to the outlet, which it is serving. In this situation attention must be paid to the maximum distance of pipe work from the mixed water outlet of the valve to any terminal fitting.
- Current guidelines recommend a maximum distance of 2 metres from the outlet of any mixing valve to the furthest terminal fitting/outlet to which the mixing valve is to serve.
- The hot and cold water supplies must be connected to the valve strictly in accordance with the indications on the body of the valve i.e. hot water supply to the hot port of the valve.
- In a situation where one or both of the water supplies are excessive, it is possible to fit a pressure reducing valve to reduce the pressure(s) to within the limits as quoted previously.
- Any thermostatic mixing valve must be fitted with a back flow prevention device, such as check valves to prevent the cross contamination of supplies. The CORE 5213 valves are complete with integral insert check valves and strainers.
- Y Pattern strainers and full-bore isolation valves must be installed in conjunction with the CORE 5213 fail-safe thermostatic mixing valves as close as is practically possible to the location of the valve. Alternatively the use of the thermostatic mixing valve with the MX end pieces removes the need for additional filters and isolation valves.

- It is essential that the CORE 5213 thermostatic mixing valves should not be installed in situations where there is a possibility of the valve being deprived of water or where demands for water are greater than the actual stored supplies.
- To ensure that the performance levels of the CORE 5213 thermostatic mixing valves are maintained (in the event of cold water failure), the temperature of the hot water supply at the point of entry to the valves must be a minimum of 10°C above the commissioned mixed water discharge temperature.
- The CORE 5213 thermostatic mixing valves must not be subject to any extreme temperature variations either during the installation or under normal operating conditions.

METHOD OF ADJUSTING THE MIXED WATER OUTLET TEMPERATURE

IMPORTANT: - The following instructions must be read and understood prior to the adjustment of the mixed water outlet temperature and this action **MUST** only be carried out by a suitably qualified person.

- Remove the cap from the valve
- Remove the temperature locking ring from the spindle using a suitably sized spanner.
- Open the outlet to which the mixing valve is supplying and establish a stable flow and temperature.
- Using a calibrated thermometer place the sensing part of the thermometer probe under the flowing water.
- Using a suitably sized spanner turn the temperature adjustment spindle anticlockwise to increase the mixed water temperature or clockwise to reduce the mixed water temperature – at all times ensuring the probe of the thermometer is under the flowing water.
- Once the desired temperature is reached – replace the temperature locking ring on the spindle and re fit the cap of the valve.
- The temperature at the terminal fitting must never exceed 46°C.

COMMISSIONING

IMPORTANT: - The following instructions must be read and understood prior to the commissioning of the CORE 5213 fail-safe thermostatic mixing valves. If under any circumstances there are aspects to the installation / system which do not comply with the specification laid down, the valve **MUST NOT** be put into operation until the system / installation complies with our specification.

- Before commissioning the thermostatic mixing valve check the following:
 - The supply pressures are within the valves operating range.
 - The supply temperatures are within the valves operating range.
 - The temperature differential is appropriate for the supply conditions.
 - Isolating valves are fitted, accessible and open.
 - Strainers are fitted and clean.
 - Appropriate Backflow prevention devices are fitted.
 - The system has been thoroughly cleaned and free from any debris.Providing that all of these conditions are met, please follow the following steps to commission this product.
- The commissioning of the temperatures must be carried out using a suitably calibrated thermometer – preferably a digital thermometer the sensing part of the thermometer probe must be fully submerged in the water when testing.
- Each valve must be commissioned taking into consideration any fluctuations, which may occur within the system due to simultaneous demands. It is advisable that any outlets which are connected to the same supply as the mixing valve is connected to, open during the setting of the mixed water temperature. During commissioning it is advisable to ensure that the water temperatures are established before any attempt to commission.
- Once the supply temperatures are stable and the normal operating conditions are established, the valve can be commissioned, – the temperature setting can be adjusted by removing the cap and temperature locking ring from the valve body (see section method of adjusting mixed water temperature). We suggest that the following sequence is followed when commissioning the valve;

COMMISSIONING CONTINUED

- Set the mixed water temperature to the required temperature, the temperature at the terminal fitting must never exceed 46°C.
- Measure and record the temperature of the hot and cold water supplies at the connection to the valve.
- Measure and record the temperature of the water discharging from the valve.
- Isolate the cold water supply to the valve and monitor the mixed water temperature.
- Measure and record the maximum mixed water temperature and the final temperature. The final temperature found during the test should not exceed the values quoted.
- Record all the equipment used during the commissioning.
- The mixed water temperature at the terminal fitting must never exceed 2°C above set temperature.
- The maximum mixed water supply temperature at the terminal fitting should not exceed 46°C.
- When satisfied that the mixed water outlet temperature is correct, check that it is consistently repeatable by turning the mixing valve on and off a number of times and rechecking the mixed water temperature. If the mixed water outlet is stable carry out the cold water isolation test.
- Once the desired temperature is established remove the cap and secure the temperature spindle with the locking ring and replace the cap into its original position to prevent tampering by unauthorized persons. Ensure that the application, in which the valve will be used, is appropriate for the approved designation.
- The above information must be recorded and updated on every occasion when any work is carried out on the valve.

COLD WATER ISOLATION TEST

The purpose of the cold water isolation test is to ensure that the thermal performance of the TMV is adequate at the time of installation and annually thereafter.

PROCEDURE:

- Operate the TMV and achieve a normal flowrate for the application and record the initial mixed water outlet temperature.
- Isolate the cold water supply to the valve.
- Collect the water discharged from the TMV outlet for 5 seconds.
- Continue to collect the water discharged from the TMV outlet in a second vessel for a further period of 30 seconds.
- Re-open (restore) the cold water supply and after 30 seconds measure the mixed water temperature.

If there is a residual flow during the commissioning or the annual verification (cold water supply isolation test), then this is acceptable providing the temperature of the water seeping from the valve is no more than 2°C above the designated maximum mixed water outlet temperature setting of the valve.

ACCEPTANCE CRITERIA FOR TUB/BATH:

- The volume collected in the first period of 5s shall not exceed 400 ml.
- The volume collected in the second period of 30s shall not exceed an additional 500ml.
- After restoration of the cold water supply (30s) the mixed water outlet temperature shall not differ by more than 2°C from the initial set mixed water temperature.

COLD WATER ISOLATION TEST CONTINUED

ACCEPTANCE CRITERIA FOR OTHER OUTLETS:

- The volume collected in the second period of 30s shall not exceed an additional 300 ml.
- After restoration of the cold water supply (30s) the mixed water outlet temperature shall not differ by more than 2°C from the initial set mixed water temperature.

IN SERVICE TESTING

The CORE 5213 thermostatic mixing valves should be tested against the original set temperature results once a year. It is a requirement that all Type 2 approved valves shall be verified against the original set temperature results once a year. Whilst this is a recommendation in user / owner domestic dwellings, a duty of care obligation should be considered in commercial bathroom or subletting situations. When in-service testing is undertaken the following performance checks shall be carried out.

- When commissioning/testing is due the following performance checks shall be carried out. When measuring any mixed water outlet temperature reading the sensing part of the thermometer probe must be fully submerged in the water. When testing is due the following performance checks shall be carried out;
- Measure the mixed water temperature at the outlet.
 - Carry out the cold water supply isolation test by isolating the cold water supply to the TMV, wait for five seconds if water is still flowing check that the temperature is below 46°C.
 - If there is no significant change to the set outlet temperature (±2°C or less change from the original settings) and the fail-safe shut off is functioning, then the valve is working correctly and no further service work is required.
 - If the performance falls outside of that acceptance criteria then service or adjust the valve in line with these instructions. Temperature readings should be taken at the normal flow rate after allowing for the system to stabilise.
 - If the CORE 5213 thermostatic mixing valves has been adjusted or serviced it must be re-commissioned and re-tested in accordance with these instructions.
 - Commissioning, maintenance and in-service test records must be kept for public buildings in accordance with any water safety plan.

SPARES

For component identification see page 16.

PROBLEM SOLVING

For resolving on site problems see page 14.

CORE TMV TYPE 3

INTRODUCTION

The CORE 5213 thermostatic mixing valves have been specifically designed and manufactured to meet the requirements of BS 7942: 2000 and NHS/DoH HTM 04-01. The valve has been independently tested and approved by Kiwa Watertec as a TYPE 3 valve under the Kiwa Watertec TMV3 Type 3 scheme.

TECHNICAL SPECIFICATION/ CONDITIONS FOR USE TYPE 3 VALVES

Outlet Temperature Adjustment Range	30°C to 50°C
Temperature Stability	±2°C
Maximum Hot Inlet Temperature	85°C
Inlet Temperature Range	55°C to 65°C : Hot Supply 5°C to 20°C : Cold Supply
Max. Working Pressure	10 bar : Static
Min. Working Pressure	0.2 bar : Dynamic
DO8 Working Pressure Range	0.2 to 1.0 bar : Low Pressure 1.0 to 5.0 bar : High Pressure
Min Temp Differential (Mix to Hot) for Fail-Safe	10°C
Max. Pressure Inlet Differential	5 : 1
Max. Flow Rate @ 1 bar Differential	Ø15mm 1500 l/hr (25 l/m) Ø22mm 1700 l/hr (28.3 l/m)

NOTE: Valves operating outside these conditions cannot be guaranteed by the Scheme to operate as Type 3 valves.

APPROVALS

Kiwa Watertec Scheme Approval Number	Details Available on Request
WRAS Scheme Approval Number	Details Available on Request

FAIL SAFE FUNCTION

The CORE 5213 valves are designed to stop the mixed water flow in the event of either the hot or cold water supply failing when installed in accordance with these instructions. To ensure full closure of the mixed water flow the minimum temperature differential between the hot water inlet to the valve and the mixed water outlet **MUST** be at least 10°C.

APPLICATION

The CORE 5213 thermostatic mixing valves have been independently tested by Kiwa Watertec and certified as meeting the requirements of the NHS D08 specification under the Type 3 Scheme as being suitable for use on the following designations;

APPLICATION

CODE	CODE	RANGE	CODE	CODE	RANGE
HP-W	Basin	High Press	LP-WE	Basin	Low Press
HP-B	Bidet	High Press	LP-BE	Bidet	Low Press
HP-S	Shower	High Press	LP-SE	Shower	Low Press
HP-T44	Bath Assisted*	High Press	* 22mm size only		
HP-T46	Bath Assisted*	High Press			

DIMENSIONS

For dimensions see pages 15 and 16.

FLOWRATES

For Kv values and flowrate - pressure loss chart see page 15.

INSTALLATION

IMPORTANT: - The following instructions must be read prior to the installation of any CORE 5213 valves. The installer should also be aware of their responsibility and duty of care to ensure that all aspects of the installation comply with all current regulations and legislation.

Flushing through water systems using certain chemicals may wholly or partially remove the lubricant from the internal workings of the valve, which may adversely affect its performance. We recommend that following a flushing of the system with chemicals, valves are checked for correct operation.

- The installation of thermostatic mixing valves must comply with the requirements of the Water Supply (Water Fittings) Regulations' 1999 and Scottish Water Byelaws.
- The Thermostatic mixing valve must be installed in such a location that maintenance of the TMV using its isolating valves and that the commissioning and testing of the TMV can be undertaken.

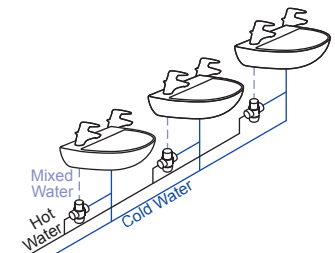

- It is essential that before installing any CORE valves ensure that the supply conditions of the system to which the valve is intended to be fitted are checked to confirm compliance with the parameters as quoted within the Technical Specification and conditions on which the approval is granted i.e. verify supply temperatures, supply pressures, risk assessment